

刃先交換式多機能エンドミル

Indexable multi-function end mill

アルファ 快削じゅうおう **AHJ**

Easy Cut Multi Function End Mill AHJ



株式会社 **MOLDINO**
MOLDINO Tool Engineering, Ltd.

New Product News | No.1003-12 | 2022-10

AJコーティングが新たにラインナップ! 超快削刃型と多機能刃型の融合

New variations of coating, introducing AJ coating series.

Fusion of "easy cutting geometry" and "multi function geometry"

01

プランジコンタリング加工
Plunge contouring

02

溝加工
Slotting

03

ドリル加工
Drilling

04

深切込み加工
Deep cutting

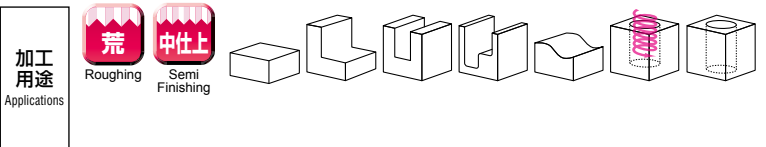
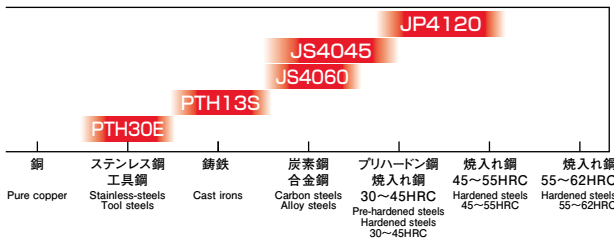
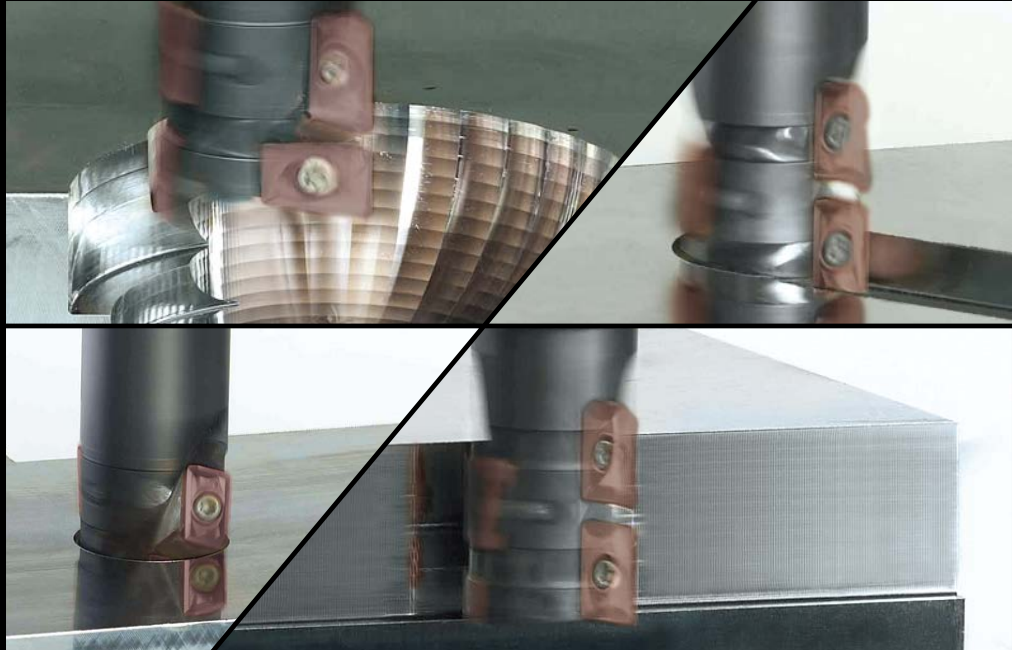

特長 Features

切れ味と刃先強度を兼ね備えたハイレキ刃形に進化しました!

下穴なしでの縦送り(ドリル)加工や傾斜・横送り加工など1本の工具で縦横無尽の加工ができる多機能、底刃付きエンドミルです。

Advanced high-rake geometry combines easy cut and edge strength.

A multi-function end mill with a bottom flute to allow unlimited horizontal and vertical cutting with a single tool. Perform drilling without a pilot hole, ramping or horizontal milling, etc.

特長及び用途 Features and Application

低抵抗快削刃形により

Since advanced high-rake geometry

- 切削領域が拡大しました
- 切削振動を低減し長突き出し時の加工でも安定切削が可能です
- ・ Expands application range.
- ・ Reduces cutting vibrations and enables stable cutting even when processing with long overhang.

高効率加工が可能です
High-efficiency machining.

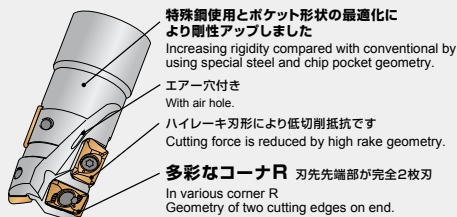

1本の工具で多彩な加工

Multi-function processing with a single tool

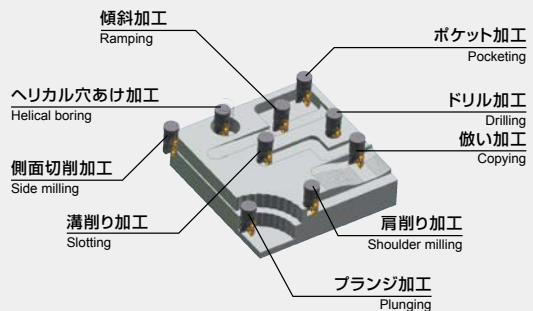

PVD Technology

プリハードン鋼・焼入れ鋼加工用材種 JP4120

Grade for machining pre-hardened or hardened materials

○ 特長 Features

- 耐摩耗性と靱性のバランスに優れた微粒超硬母材と新コーティング「AJコーティング」の採用により耐摩耗性と耐チッピング性を向上させました。
 - 汎用性が高く、30～50HRCの鋼材の切削加工で耐摩耗性と耐チッピング性に優れます。
- Employs a fine carbide substrate with an excellent balance between wear resistance and toughness and the new "AJ Coating" to provide improved wear resistance and chipping resistance.
- Highly versatile with excellent wear resistance and chipping resistance when machining steel materials with hardnesses of 30 to 50 HRC.

○ 得意分野 Strong fields

- 30～50HRCのプリハードン鋼・焼入れ鋼の切削加工において優れた切削性能を発揮します。
 - 難削系のダイカスト金型用鋼や析出硬化系ステンレス鋼、仕上げ加工においても優れた耐摩耗性を発揮します。
- Exhibits excellent cutting performance when machining pre-hardened or hardened steels with hardnesses of 30 to 50 HRC.
- Exhibits excellent wear resistance even on difficult-to-cut diecast tool steels or precipitation-hardened stainless steels, or for finishing.

切削性能 Cutting performance

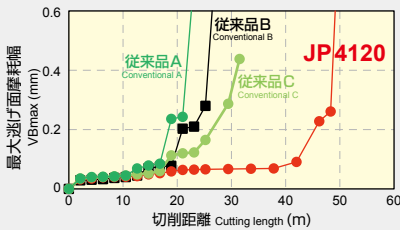

ワーク Work material : P21 (40HRC)
 使用工具 Tool : ASRT5063R-4
 インサート Insert : WDNW140520
 切削条件 Cutting conditions :
 $v_c=90\text{m/min}$ $f_z=0.8\text{mm/t}$
 $a_p \times a_e=1 \times 44\text{mm}$
 乾式加工 Dry
 ※単一刃加工 Single-flute cutting

PVD Technology

鋼一般加工用材種 JS4045

General purpose for steel

○ 特長 Features

- 耐熱性に優れたコーティング膜の採用により、高能率加工で発生するクレータ摩耗を低減しました。
 - 耐熱性の高い超硬母材の採用により、摩耗の進行が低減し工具寿命に優れます。
 - 特に乾式加工において長寿命が図れます。
- JS4045 adopts heat resistant layer, reduces the crater wear by high-speed cutting.
- JS4045 adopts heat resistant substrate, reduces the wear and improves tool life.
- Improves tool life on dry cutting.

○ 得意分野 Strong fields

- SS材、SC材、SCM材などの35HRC未満の連続～軽断続加工までの乾式加工。
- continuous and light interrupted cutting of less than 35HRC dry cutting.

皮膜の組織 JSコーティング

Layer structure JS Coating

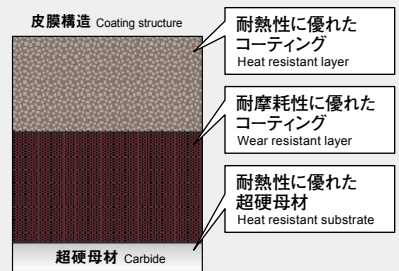

○ 切削性能 Cutting performance

SCM440 (32HRC) の切削試験結果 Wear graph after cutting SCM440 (32HRC)

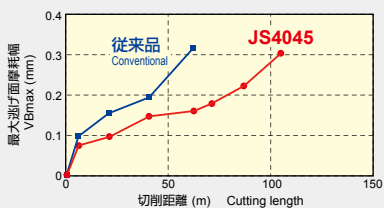

切削条件 Cutting Conditions

被削材 Work Material : SCM440(32HRC)
 工具 Tool : ASRS5063-4
 インサート型番 Insert Model : EDNW15T4TN-15
 切削速度 Cutting Speed : $v_c = 180\text{m/min}$
 1刃当りの送り量 Feed per tooth : $f_z = 1.5\text{mm/t}$
 切り込み Cutting depth : $a_p \times a_e = 1.0 \times 42\text{mm}$
 切削油剤 Coolant : Dry (Air)加工 単一刃切削
 Dry cutting Single-flute cutting

P20 (32HRC) の切削試験結果 Wear graph after cutting P20 (32HRC)

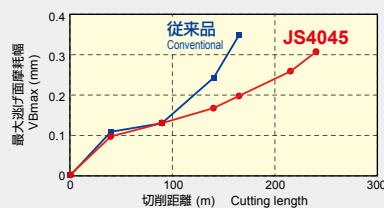

切削条件 Cutting Conditions

被削材 Work Material : P20(32HRC)
 工具 Tool : ASRS2016R-2
 インサート型番 Insert Model : EPNW0603TN-8
 切削速度 Cutting Speed : $v_c = 180\text{m/min}$
 1刃当りの送り量 Feed per tooth : $f_z = 1.5\text{mm/t}$
 切り込み Cutting depth : $a_p \times a_e = 0.5 \times 13\text{mm}$
 切削油剤 Coolant : Dry (Air)加工 単一刃切削
 Dry cutting Single-flute cutting

切削性能

Cutting performance

01 切削抵抗 Reduced cutting force

● AHJは独自のハイレーキ刃形とインサート配置により、切削振動及び抵抗を最小限に抑えた快削形工具です。

• AHJ uses our original high-rake geometry and insert positioning to provide comfortable cutting by suppressing cutting force and cutting vibration changes to a minimum.

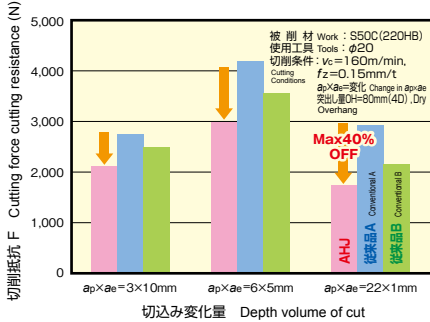

02 切削領域 Application Range

● 切削抵抗低減の効果により、切削領域は従来品に比べ拡大しています。

• By reducing cutting force, the application range is greatly expanded compared to conventional products.

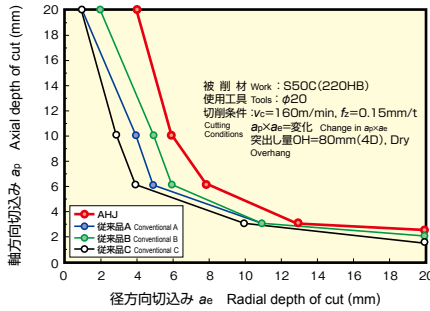

03 刃先強度 Edge strength

● 快削性に加え十分な刃先強度も兼ね備えています。

• Combines cutting comfort with tough edge strength.

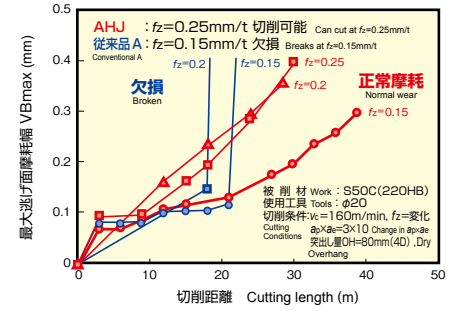

切削事例

Field data

01 AHJ25R による加工半減事例 Example of reducing processing by half with AHJ25R

ワーク Work: 機械部品のポケット加工 Pocketting of mechanical part
工具 Tool: AHJ25R

Y	工具費 Tool cost	(¥/工具) (¥/Tool)
P	工具寿命 Tool life	(ワーク/工具) (Work/Tool)
Td	工具交換時間 Tool change time	(分/工具) (min/Tool)
M	機械費 Machine charge(チャージ)	(¥/分) (¥/min)
Tc	加工時間 Cutting time	(分/ワーク) (min/Work)
K	加工費 Cutting cost	(¥/ワーク) (min/Work)
	加工費比率 Processing cost ratio	(%)
	月間加工費削減 Reduced monthly processing costs	(¥/月) (¥/month)

従来 Conventional	提案 Proposal
従来品 Conventional	AHJ25R
¥3,200	¥3,840
10	12
2	2
¥60	¥60
14.0	3.4
¥1,172	¥534
100%	46%
	¥720,565

◎下記の式にて計算します。 Calculated using the formula below:

$$\text{加工費} : K = M \times Tc + \frac{(Y + M \times Td)}{P} \quad (\text{注}) \text{機械費は推定値です。}$$

Basic unit of CO₂ exhaust volume per chip basic unit (g-CO₂/cm³) (g-CO₂/cm³)
環境負荷比率 Environmental load ratio (%)

従来 Conventional	提案 Proposal
1.378	0.475
100%	35%

加工費: 54%削減 Cutting cost: Reduced by 54%

CO₂発生率: 65%削減 CO₂ emission ratio: Reduced by 65%

02 AHJ50R による加工半減事例 Example of reducing processing by half with AHJ50R

ワーク Work: 機械部品のポケット加工 Pocketting of mechanical part
工具 Tool: AHJ50R

Y	工具費 Tool cost	(¥/工具) (¥/Tool)
P	工具寿命 Tool life	(ワーク/工具) (Work/Tool)
Td	工具交換時間 Tool change time	(分/工具) (min/Tool)
M	機械費 Machine charge(チャージ)	(¥/分) (¥/min)
Tc	加工時間 Cutting time	(分/ワーク) (min/Work)
K	加工費 Cutting cost	(¥/ワーク) (min/Work)
	加工費比率 Processing cost ratio	(%)
	月間加工費削減 Reduced monthly processing costs	(¥/月) (¥/month)

従来 Conventional	提案 Proposal
従来品 Conventional	AHJ50RS
¥3,800	¥4,000
2	3
10	10
¥60	¥60
50	35
¥5,200	¥3,633
100%	70%
	¥171,886

◎下記の式にて計算します。 Calculated using the formula below:

$$\text{加工費} : K = M \times Tc + \frac{(Y + M \times Td)}{P} \quad (\text{注}) \text{機械費は推定値です。}$$

Basic unit of CO₂ exhaust volume per chip basic unit (g-CO₂/cm³) (g-CO₂/cm³)
環境負荷比率 Environmental load ratio (%)

従来 Conventional	提案 Proposal
1.267	0.462
100%	36%

加工費: 30%削減 Cutting cost: Reduced by 30%

CO₂発生率: 64%削減 CO₂ emission ratio: Reduced by 64%

ストレートシャンクタイプ

Straight Shank type

AHJ (L) ○ ○ R

標準 刃長形 Regular flute

○は数字が入ります。Numeric figure in a circle ○.

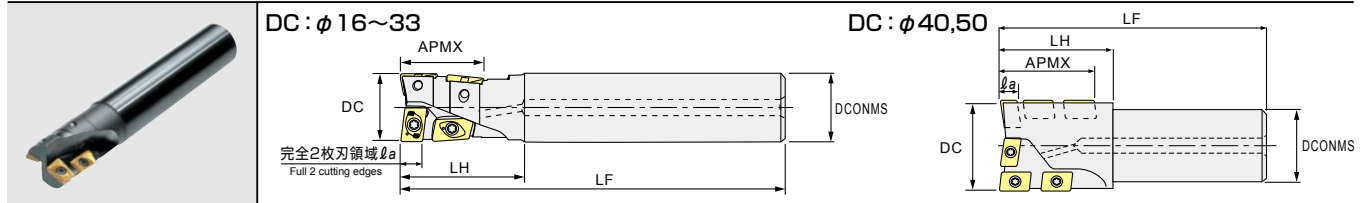

商品コード Item code	在庫 Stock	寸法 Size(mm)							適用インサート Inserts						希望小売 価格(円) Suggested retail price (¥)
		DC	LF	ℓa	APMX	LH	DCNMS	底刃用 On end		外周刃用 On periphery					
		商品コード Item Code	使用数 No. of inserts	商品コード Item Code	使用数 No. of inserts										
標準形 Regular	AHJ16R	●	16	120	4.5	19	33	16	JDMT0803○○L	1	JDMT0903○○R	3	37,430		
	AHJ20R	●	20	130	5.5	23	35	20	JDMT1003○○L	1	JDMT1003○○R	3	40,010		
	AHJ25R	●	25	140	7.0	29	45	25	JDMT12T3○○L	1	JDMT12T3○○R	3	41,300		
	AHJ32R	●	32	150	8.5	34	50	32	JDMT1605○○L	1	JDMT1505○○R	3	45,170		
	AHJ40R	●	40	160	7.0	40	55	32	JDMT12T3○○L	2	JDMT12T3○○R	4	54,200		
	AHJ50R	●	50	170	8.5	50	70	42	JDMT1605○○L	2	JDMT1505○○R	4	64,990		
ロングシャンク形 Long shank	AHJL16R	●	16	175	4.5	19	50	16	JDMT0803○○L	1	JDMT0903○○R	3	41,300		
	AHJL17R	●	17				33						41,300		
	AHJL20R	●	20	185	5.5	23	60	20	JDMT1003○○L	1	JDMT1003○○R	3	43,880		
	AHJL21R	●	21				35						43,880		
	AHJL25R	●	25	220	7.0	29	75	25	JDMT12T3○○L	1	JDMT12T3○○R	3	45,170		
	AHJL26R	●	26				45						45,170		
	AHJL32R	●	32	230	8.5	34	90	32	JDMT1605○○L	1	JDMT1505○○R	3	49,040		
	AHJL33R	●	33				50						49,040		
	AHJL40R	●	40	240	7.0	40	55	32	JDMT12T3○○L	2	JDMT12T3○○R	4	58,070		
	AHJL50R	●	50	250	8.5	50	70	42	JDMT1605○○L	2	JDMT1505○○R	4	68,630		

AHJ (L) ○ ○ RS

短 刃長形 Short flute

○は数字が入ります。Numeric figure in a circle ○.

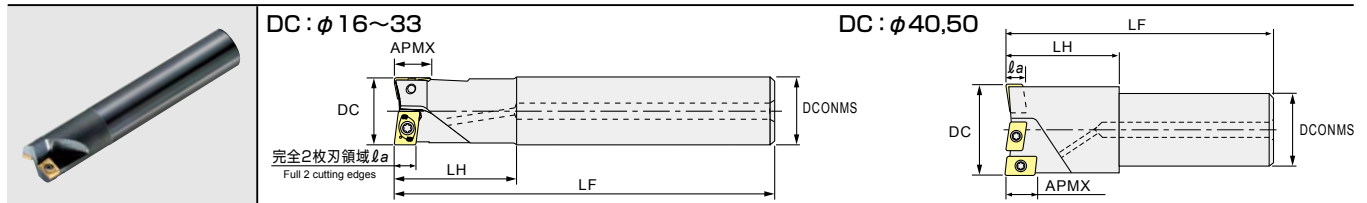

商品コード Item code	在庫 Stock	寸法 Size(mm)							適用インサート Inserts						希望小売 価格(円) Suggested retail price (¥)
		DC	LF	ℓa	APMX	LH	DCNMS	底刃用 On end		外周刃用 On periphery					
		商品コード Item Code	使用数 No. of inserts	商品コード Item Code	使用数 No. of inserts										
標準形 Regular	AHJ16RS	●	16	120	4.5	8.5	33	16	JDMT0803○○L	1	JDMT0903○○R	1	28,040		
	AHJ17RS	●	17										28,040		
	AHJ20RS	●	20	130	5.5	9.5	35	20	JDMT1003○○L	1	JDMT1003○○R	1	29,920		
	AHJ21RS	●	21										29,920		
	AHJ25RS	●	25	140	7.0	12.5	45	25	JDMT12T3○○L	1	JDMT12T3○○R	1	30,970		
	AHJ26RS	●	26										30,970		
	AHJ32RS	●	32	150	8.5	14.5	50	32	JDMT1605○○L	1	JDMT1505○○R	1	33,790		
	AHJ33RS	●	33										33,790		
	AHJ40RS	●	40	160	7.0	12.5	55	32	JDMT12T3○○L	2	JDMT12T3○○R	1	40,710		
AHJ50RS	●	50	170	8.5	14.5	70	42	JDMT1605○○L	2	JDMT1505○○R	1	48,810			
ロングシャンク形 Long shank	AHJL16RS	●	16	175	4.5	8.5	50	16	JDMT0803○○L	1	JDMT0903○○R	1	31,920		
	AHJL17RS	●	17				33						31,920		
	AHJL20RS	●	20	185	5.5	9.5	60	20	JDMT1003○○L	1	JDMT1003○○R	1	32,980		
	AHJL21RS	●	21				35						32,980		
	AHJL25RS	●	25	220	7.0	12.5	75	25	JDMT12T3○○L	1	JDMT12T3○○R	1	33,790		
	AHJL26RS	●	26				45						33,790		
	AHJL32RS	●	32	230	8.5	14.5	90	32	JDMT1605○○L	1	JDMT1505○○R	1	36,840		
	AHJL33RS	●	33				50						36,840		
	AHJL40RS	●	40	240	7.0	12.5	55	32	JDMT12T3○○L	2	JDMT12T3○○R	1	43,530		
	AHJL50RS	●	50	250	8.5	14.5	70	42	JDMT1605○○L	2	JDMT1505○○R	1	51,390		



ラインナップ

Line Up

モジュラータイプ

Modular type

AHJM RS









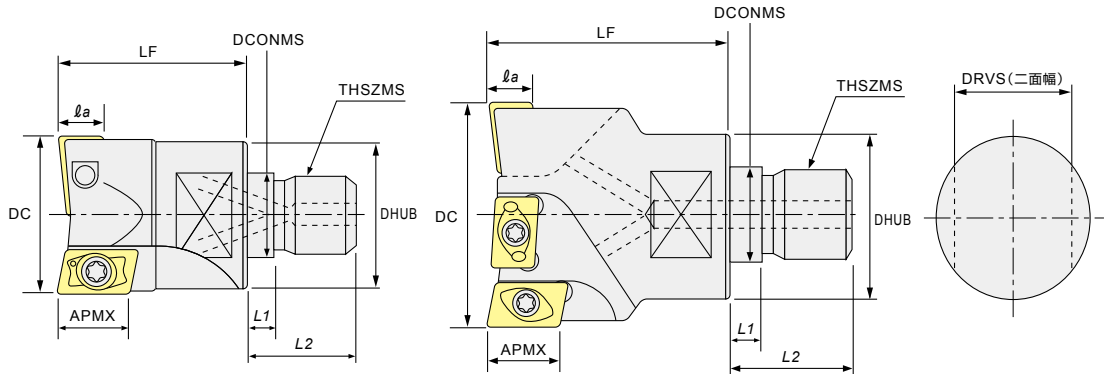

は数字が入ります。Numeric figure in a circle .



DC: ϕ 16~33

DC: ϕ 40



商品コード Item code	在庫 Stock	寸法 Size(mm)										使用インサート Inserts				希望小売 価格(円) Suggested retail price (¥)	
		DC	LF	l_a	APMX	DCONMS	THSZMS	DHUB	L1	L2	DRVS	底刃用 On end		外周刃用 On periphery			
												商品コード Item code	使用数 No. of inserts	商品コード Item code	使用数 No. of inserts		
短 刃 長 形 Short flute	AHJM16RS	●	16	25	4.5	8.5	8.5	M8	12.8	5.5	17	10	JDMT0803  L	1	JDMT0903  R	1	28,040
	※ AHJM17RS	●	17														28,040
	AHJM20RS	●	20	30	5.5	9.5	10.5	M10	17.8	5.5	19	15	JDMT1003  L	1	JDMT1003  R	1	29,920
	※ AHJM21RS	●	21														29,920
	AHJM25RS	●	25	35	7	12.5	12.5	M12	20.8	5.5	22	17	JDMT12T3  L	1	JDMT12T3  R	1	30,970
	※ AHJM26RS	●	26														23
	AHJM32RS	●	32	40	8.5	14.5	17	M16	28.8	6	23	22	JDMT1605  L	1	JDMT1505  R	1	33,790
	※ AHJM33RS	●	33														33,790
	※ AHJM40RS	●	40	40	7	12.5	17	M16	28.8	6	23	22	JDMT12T3  L	2	JDMT12T3  R	1	40,710

【注意】※と超硬シャンクをセットで使用すると干渉がありません。

モジュラーミル及び専用シャンク、専用アーバの「工具端面」「モジュラーねじ部」にグリースなどの潤滑剤は塗布しないでください。

【Note】 When ※ and carbide shank are used together as a set, there is no interference.

Do not apply lubricants such as grease, etc. to the "contact faces" and "modular screws" of the "modular mill", "dedicated shanks" and "dedicated arbor".

部品番号

Parts

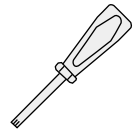
部品名 Parts	クランプねじ Clamp screw	ドライバー Screw driver
形状 Shape		
適用カット Cutter body	締付トルク Fastening torque (N·m)	希望小売価格 (円) Suggested retail price(¥)
ϕ 16/17...AHJ(L)16/17R(S) AHJM16/17RS	250-140	0.5
ϕ 20/21...AHJ(L)20/21R(S) AHJM20/21RS	251-141	1.1
ϕ 25/26...AHJ(L)25/26R(S) AHJM25/26RS	265-143	2.0
ϕ 32/33...AHJ(L)32/33R(S) AHJM32/33RS	412-141	2.9
ϕ 40...AHJ(L)40R(S) AHJM40RS	265-143	2.0
ϕ 50...AHJ(L)50R(S)	412-141	2.9
		希望小売価格 (円) Suggested retail price(¥)
		104-T6
		1,800
		104-T8
		1,800
		104-T10
		1,920
		104-T15
		2,060
		104-T10
		1,920
		104-T15
		2,060

【注意】クランプねじは消耗品です。使用環境により交換寿命は変化しますので早めの交換をお願い致します。

【Note】 The clamp screw is a consumable part. Since replacement life depends on the use environment, it is recommended that it be replaced at an early stage.

●印：標準在庫品です。●：Stocked Items. 無印：受注生産品です。No Mark:Manufactured upon request only.

インサート

Inserts

Fig.1 底刃用インサート
Inserts on end

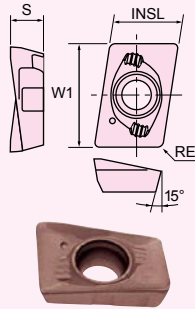
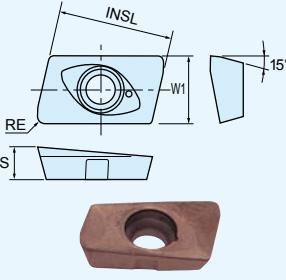
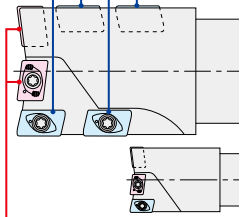
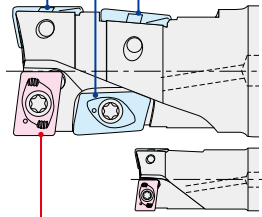

Fig.2 外周刃用インサート
Inserts on periphery



φ16~φ33

φ40, φ50



φ16~φ33

φ40

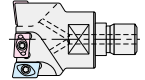
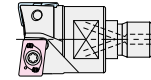

[注意] $R \geq 2.0$ のインサートを使用する場合はポデーコーナ部を追加加工する必要があります。
[Note] When using the insert with $R \geq 2.0$, it is necessary to carry out additional processing of cutter body corner part.

P	鋼 Carbon steels		M	SUS等 SUS, etc.		K	FC・FCD Cast irons		■	□	■	□	■	□	■	□	■	□	■	□	■	□	■	□
	■	□		■	□		■	□																
適用インサート Inserts																								
外径 DC Tool dia.	コーナ R Corner R	インサート取付け位置 Position	商品コード Item code	※ 使用数 No. of inserts	精度 Tolerance class	AJ コーティング AJ Coating	JS コーティング JS Coating	TH コーティング TH Coating	寸法 Size(mm)				希望小売価格(円) Suggested retail price (¥)											
						JP4120	JS4045	JS4060	PTH30E	PTH13S	INSL	W1	S	RE										
φ16	R0.4	底刃用 On end Fig.1	JDMT080304L	1	M級 M	●	●	●	●		5.3	7.8	3.0	0.4	970									
		外周刃用 On periphery Fig.2	JDMT090304R	3(1)		●	●	●	●		9.2	5.0	2.8	0.4	970									
φ17	R0.8	底刃用 On end Fig.1	JDMT080308L	1		●	●	●	●	●		5.3	7.8	3.0	0.8	970								
		外周刃用 On periphery Fig.2	JDMT090308R	3(1)		●	●	●	●	●		9.2	5.0	2.8	0.8	970								
φ20	R0.4	底刃用 On end Fig.1	JDMT100304L	1		●	●	●	●	●		6.3	9.8	3.2	0.4	1,310								
		外周刃用 On periphery Fig.2	JDMT100304R	3(1)		●	●	●	●	●	[●]	11.0	6.1	3.5	0.4	1,310								
	R0.8	底刃用 On end Fig.1	JDMT100308L	1		●	●	●	●	●		6.3	9.8	3.2	0.8	1,310								
		外周刃用 On periphery Fig.2	JDMT100308R	3(1)		●	●	●	●	●		11.0	6.1	3.5	0.8	1,310								
	R2.0	底刃用 On end Fig.1	JDMT100320L	1		●	●	●	●	●		6.3	9.8	3.2	2.0	1,310								
		外周刃用 On periphery Fig.2	JDMT100320R	1		●	[●]	●	●	●		11.0	6.1	3.5	2.0	1,310								
		外周刃用 On periphery Fig.2	JDMT100308R	2(0)		●	[●]	●	●	[●]		11.0	6.1	3.5	0.8	1,310								
φ25	R0.8	底刃用 On end Fig.1	JDMT12T308L	1		●	●	●	●	●		7.9	12.3	3.9	0.8	1,370								
		外周刃用 On periphery Fig.2	JDMT12T308R	3(1)		●	●	●	●	●		13.6	8.0	3.9	0.8	1,370								
	R2.0	底刃用 On end Fig.1	JDMT12T320L	1		●		●	●	●		7.9	12.3	3.9	2.0	1,370								
		外周刃用 On periphery Fig.2	JDMT12T320R	1		●		●	●	●		13.6	8.0	3.9	2.0	1,370								
	R3.0	底刃用 On end Fig.1	JDMT12T330L	1		●		●	●	●		7.9	12.3	3.9	3.0	1,370								
		外周刃用 On periphery Fig.2	JDMT12T330R	1		●		●	●	●		13.6	8.0	3.9	3.0	1,370								
		外周刃用 On periphery Fig.2	JDMT12T308R	2(0)		●	[●]	●	●	[●]		13.6	8.0	3.9	0.8	1,370								
φ32	R0.8	底刃用 On end Fig.1	JDMT160508L	1		●	●	●	●	●		9.5	15.8	5.0	0.8	1,490								
		外周刃用 On periphery Fig.2	JDMT150508R	3(1)		●	●	●	●	●		16.0	9.1	5.0	0.8	1,490								
	R3.0	底刃用 On end Fig.1	JDMT160530L	1		●		●	●	●		9.5	15.8	5.0	3.0	1,490								
		外周刃用 On periphery Fig.2	JDMT150530R	1		●	[●]	●	●	●		16.0	9.1	5.0	3.0	1,490								
			外周刃用 On periphery Fig.2	JDMT150508R		2(0)	●	[●]	●	●	[●]		16.0	9.1	5.0	0.8	1,490							
			外周刃用 On periphery Fig.2	JDMT150508R		2(0)	●	[●]	●	●	[●]		16.0	9.1	5.0	0.8	1,490							
φ40	R0.8	底刃用 On end Fig.1	JDMT12T308L	2	●	●	●	●	●		7.9	12.3	3.9	0.8	1,370									
		外周刃用 On periphery Fig.2	JDMT12T308R	4(1)	●	●	●	●	●		13.6	8.0	3.9	0.8	1,370									
	R2.0	底刃用 On end Fig.1	JDMT12T320L	1	●		●	●	●		7.9	12.3	3.9	2.0	1,370									
		外周刃用 On periphery Fig.2	JDMT12T320R	1	●		●	●	●		13.6	8.0	3.9	2.0	1,370									
	R3.0	底刃用 On end Fig.1	JDMT12T308L	1	●		●	●	●		7.9	12.3	3.9	0.8	1,370									
		外周刃用 On periphery Fig.2	JDMT12T308R	3(0)	●		●	●	●		13.6	8.0	3.9	0.8	1,370									
		外周刃用 On periphery Fig.2	JDMT12T330R	1	●		●	●		13.6	8.0	3.9	3.0	1,370										
φ50	R0.8	底刃用 On end Fig.1	JDMT160508L	2	●	●	●	●	●		9.5	15.8	5.0	0.8	1,490									
		外周刃用 On periphery Fig.2	JDMT150508R	4(1)	●	●	●	●	●		16.0	9.1	5.0	0.8	1,490									
	R3.0	底刃用 On end Fig.1	JDMT160530L	1	●		●	●	●		9.5	15.8	5.0	3.0	1,490									
		外周刃用 On periphery Fig.2	JDMT160508L	1	●		●	●	●		9.5	15.8	5.0	0.8	1,490									
			外周刃用 On periphery Fig.2	JDMT150530R	1	●	[●]	●	●	[●]		16.0	9.1	5.0	3.0	1,490								
			外周刃用 On periphery Fig.2	JDMT150508R	3(0)	●	[●]	●	●	[●]		16.0	9.1	5.0	0.8	1,490								

[]: 底刃用と同じ材種がないため推奨いたしません。 []: Since the same insert grade is not used for the bottom flute, it is not recommended.

※: (カッコ)内は短刃長形とモジュラーミルのインサート使用数です。※: Numbers in parentheses are the number of inserts when using a short flute and Modular Mill.

[注意] JSコートは通電式タッチセンサーに反応しませんのでご注意ください。 **[Note]** Please note that the JS coating does not cause a reaction in conductive touch sensors.

ラインナップ

Line Up

モジュラーミル専用シャンク

The Shanks for Modular Mill

超硬シャンク Carbide Shank

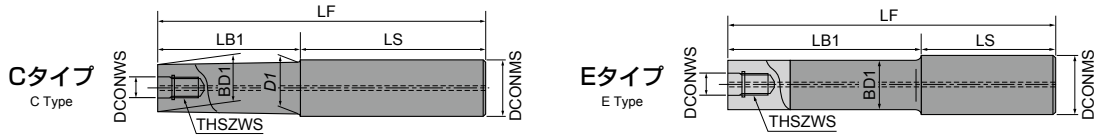

商品コード Item code	在庫 Stock	寸法 Size(mm)								タイプ Type	適用カッタ Cutter body	備考 Note	希望小売価格(円) Suggested retail price (¥)
		DCONWS	THSZWS	LF	LB1	LS	BD1	DCONMS	D1				
ASC16-8.5-95-30Z	●	8.5	M8	95	30	65	14.5	16	15.5	C	φ16 φ17 φ18	エア ー 穴 付 With Air hole	48,100
ASC16-8.5-120-55Z	●			120	55	65							52,560
ASC16-8.5-140-75Z	●			140	75	65							55,960
ASC16-8.5-160-95Z	●			160	95	65							58,900
※2 ASC16-8.5-160-30Z	●			160	30	130							58,900
ASC20-10.5-120-50Z	●	10.5	M10	120	50	70	18.5	20	19.5	C	φ20 φ21 φ22		56,780
ASC20-10.5-170-90Z	●			170	90	80							63,590
ASC20-10.5-220-120Z	●			220	120	100							69,920
ASC20-10.5-270-150Z	●			270	150	120							88,690
※2 ASC20-10.5-220-50Z	●	10.5	M10	220	50	170	18.5	20	19.5	C	φ20, φ21 φ22		88,920
※2 ASC20-10.5-270-50Z	●			270	220	88,690							
ASC25-12.5-145-65	●	12.5	M12	145	65	80	23	25	—	E	φ25 φ26 φ28		64,990
ASC25-12.5-215-115	●			215	115	100						76,130	
ASC25-12.5-265-145	●			265	145	120						88,690	
ASC25-12.5-315-195	●			315	195	120						114,370	
※2 ASC25-12.5-265-65	●	12.5	M12	265	65	200	23	25	—	E	φ25, φ26 φ28	88,690	
※2 ASC25-12.5-315-65	●			315	250	114,370							
ASC32-17-160-80	●	17	M16	160	80	80	28	32	—	E	φ30 φ32 φ33 φ35 φ40	98,540	
ASC32-17-210-110	●			210	110	100						99,710	
ASC32-17-260-140	●			260	140	120						118,480	
ASC32-17-310-190	●			310	190	120						160,710	
ASC32-17-360-240	●			360	240	120						202,930	
※2 ASC32-17-260-80	●			260	80	180						118,480	
※2 ASC32-17-310-80	●	310	230	80	160,710								
※2 ASC32-17-360-80	●	360	280	80	202,930								

【注意】 ①※2と※1 (P6) をセットで使用すると干渉がありません。
②市販のツーリング、焼ばめホルダーにて使用できます。
③(φ40) 寸法は、突き出し長さ200mm以下を目安にご使用下さい。

【Note】 ①When※2 and※1 (P6) are used together as a set, there is no interference.
②Commercial milling chucks or shrink-fit holders can be used.
③For the φ40 size, it is recommended that the overhang is 200mm or less.

鋼シャンク Steel Shank

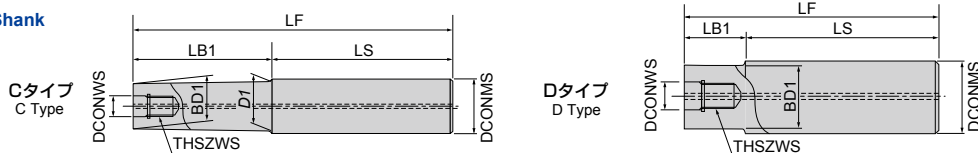

商品コード Item code	在庫 Stock	寸法 Size(mm)								タイプ Type	適用カッタ Cutter body	備考 Note	希望小売価格(円) Suggested retail price (¥)
		DCONWS	THSZWS	LF	LB1	LS	BD1	DCONMS	D1				
AS16-8.5-95-15	●	8.5	M8	95	15	80	14.5	16	15.5	C	φ16, φ17 φ18	エア ー 穴 付 With Air hole	28,160
AS20-10.5-100-20	●	10.5	M10	100	20	80	18	20	—	D	φ20, φ21 φ22		31,680
AS25-12.5-115-35	●	12.5	M12	115	35	80	23	25	—	D	φ25, φ26 φ28		35,440
AS32-17-110-30	●	17	M16	110	30	80	28	32	—	D	φ30, φ32 φ33, φ35 φ40		42,470

【注意】市販のツーリングにて使用できます。 **【Note】**Commercial milling chucks can be used.

鋼シャンク Steel Shank

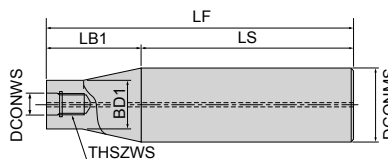

※首部及び全長は、ユーザーにて追加加工可能です。
※For neck section or total length, additional machining to user specifications is possible.

商品コード Item code	在庫 Stock	寸法 Size(mm)							適用カッタ Cutter body	備考 Note	希望小売価格(円) Suggested retail price (¥)
		DCONWS	THSZWS	LF	LB1	LS	BD1	DCONMS			
AS42-17-360-90	●	17	M16	360	90	270	28	42	φ30 φ32 φ35 φ40	エア ー 穴 付 With Air hole	80,940

【注意】市販のツーリングにて使用できます。 **【Note】**Commercial milling chucks can be used.

●印：標準在庫品です。 ●：Stocked Items. 無印：受注生産品です。 No Mark:Manufactured upon request only.

モジュラーミル用アーバ

Modular Mill Arbor

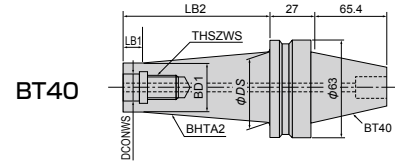
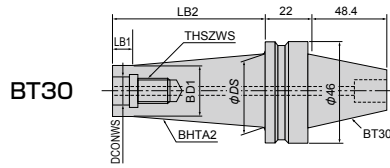

※ 首部及び全長は、ユーザー様にて追加加工可能です。
 ※ For neck section or total length, additional machining to user specifications is possible.

商品コード Item code	在庫 Stock	寸法 Size (mm)							備考 Note
		DCONWS	THSZWS	BD1	φDS	LB2	LB1	BHTA2	
BT30-8.5-25-15		8.5	8	15	30	25	5	20.6°	エア 穴付 With Air hole
BT30-8.5-50-15	50					10	10.6°		
BT30-8.5-75-15	75					10	6.6°		
BT30-10.5-20-18		10.5	10	18	35	20	5	29.5°	
BT30-10.5-45-18	45					10	13.7°		
BT30-10.5-70-18	70					10	8.1°		
BT30-12.5-15-21		12.5	12	21	40	15	5	32.3°	
BT30-12.5-40-21	40					10	17.6°		
BT30-12.5-65-21	65					10	9.8°		
BT30-12.5-85-21	85					10	7.2°		
BT30-17-10-28		17	16	28	40	10	5	31°	
BT30-17-35-28	35					10	13.5°		
BT30-17-60-28	60					10	6.8°		
BT40-8.5-25-15		8.5	8	15	30	25	5	20.6°	
BT40-8.5-50-15	50					10	10.6°		
BT40-8.5-75-15	75					10	6.6°		
BT40-8.5-125-15						125	10	3.7°	
BT40-10.5-20-18		10.5	10	18	35	20	5	29.5°	
BT40-10.5-45-18	45					10	13.7°		
BT40-10.5-70-18	70					10	8.1°		
BT40-10.5-120-18						120	10	4.4°	
BT40-12.5-15-21		12.5	12	21	40	15	5	32.3°	
BT40-12.5-40-21	40					10	17.6°		
BT40-12.5-65-21	65					10	9.8°		
BT40-12.5-115-21	115					10	5.2°		
BT40-17-10-28		17	16	28	48	10	5	45°	
BT40-17-35-28	35					10	21.8°		
BT40-17-60-28	60					10	11.3°		
BT40-17-110-28						110	10	5.7°	

【注意】 モジュラーミル用 BT30 アーバご使用の際は、標準切削条件表を目安に加工条件を決定して下さい。加工状況により振動が懸念される場合は、
 1. 切り込み深さ (ap) を低減する 2. 一刃当りの送り (fz) を低減する方法で調整下さい。

【Note】 When using the BT30 arbor for modular mills, determine the processing conditions using the standard cutting conditions table as a general guide. If vibrations are a concern due to the processing conditions, adjust conditions by 1.reducing cutting depth (ap) or 2.reducing per-flute feed rate (fz).

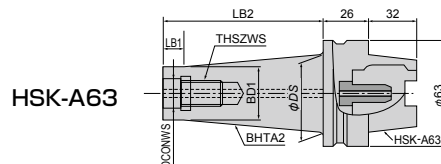

商品コード Item code	在庫 Stock	寸法 Size (mm)							備考 Note	希望小売価格 (円) Suggested retail price (¥)
		DCONWS	THSZWS	BD1	φDS	LB2	LB1	BHTA2		
HSK-A63-10.5-30-18	●	10.5	10	18	20.8	30	—	3°	エア 穴付 With Air hole	94,560
HSK-A63-10.5-70-18	●				25	70	10	3°		97,130
HSK-A63-10.5-70-18S	●				48	70	10	12°		—
HSK-A63-10.5-120-18	●				30.2	120	10	3°		101,350
HSK-A63-12.5-35-21	●	12.5	12	21	24.3	35	—	3°		95,490
HSK-A63-12.5-65-21	●				27.5	65	10	3°		96,660
HSK-A63-12.5-65-21S	●				48	65	10	12°		—
HSK-A63-12.5-115-21	●				32.7	115	10	3°		101,710
HSK-A63-17-40-28	●	17	16	28	31.8	40	—	3°		95,490
HSK-A63-17-60-28	●				33.9	60	10	3°		96,660
HSK-A63-17-60-28S	●				48	60	10	9.5°		—
HSK-A63-17-110-28	●				39.2	110	10	3°		101,120

【注意】 クーラントパイプは付属しております。 【Note】 Coolant Pipe is attached.

アーバ (BT, HSK) の特長 Arbor (BT, HSK) Features

！ポイント！

Point
 ヘッド交換式工具用アーバ (BT, HSK) は、工具突出し長さを最短に出来るシステムですので、工具の振動を抑制できます。

Reduce the chattering vibration by BT, HSK arbor due to the reduction in the "actual" overhang.

図 (例) 突出し長さの比較…最短の組合せ Example : Overhang and Application Area

カッタ Cutter : AHJM20RS
 アーバ Arbor : BT30-10.5-20-18

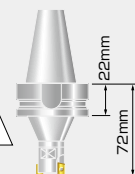

カッタ Cutter : AHJM20RS
 アーバ Arbor : 市販ミーリングチャック (BT30タイプ)
 Commercial milling chuck (BT30 type)

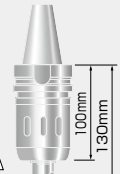

ラインナップ

Line Up

レッドスクレーパー

Red screw arbor

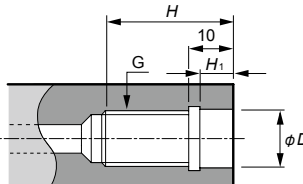
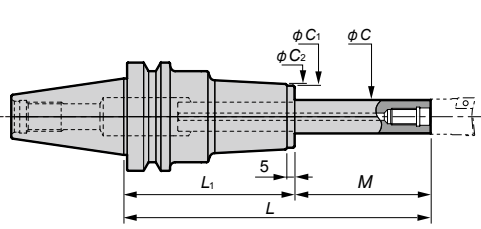

モジュラーミル 取付け部

Dimensions for the Modular Mill mounting

■注意事項 Caution

- 一部取付けできない交換式工具があります。取付け可能な「交換式工具取付部」で寸法を確認いただくか、弊社までお問合わせください。
- ※の商品は、条件を工具の推奨条件の半分程度に落としてご使用ください。機械とシャンクとの結合力に比べ、切削抵抗が大きくなり、ホルダシャンク部でフレッチング現象またはホルダの抜けが発生します。
- Some of the indexable end mills cannot be attached to the RED screw arbor. Please check your indexable end mills for conformance to the dimensions, or please contact MOLDINO Tool Engineering, Ltd.
- Because cutting resistance is greater than the tool holder connection force associated with the machine spindle, please reduce the recommended cutting conditions by 50% for the RED screw arbors marked with ※. Otherwise, the tool holder shank may experience fretting corrosion or fall out of the machine spindle.

商品コード Item code	在庫 Stock	寸法 Size(mm)										剛性値 (μm) Rigidity value δ↓			
		G	φD	H	H ₁	φC	L	M	L ₁	φC ₁	φC ₂	Weight	δ↓		
BT40-RSG8-105-M25						105		80						1.4	0.6
BT40-RSG8-135-M25						135	25	110						1.8	0.7
BT40-RSG8-165-M25						165		140						2.1	0.8
BT40-RSG8-130-M50						130		80						1.4	1.5
BT40-RSG8-160-M50						160	50	110						1.8	1.7
BT40-RSG8-190-M50						190		140						2.1	1.8
BT40-RSG8-155-M75						155		80						1.5	3.1
BT40-RSG8-185-M75	M8	8.5	18	6.5	15	185	75	110	30	32				1.9	3.4
BT40-RSG8-215-M75						215		140						2.2	3.5
BT40-RSG8-170-M90						170		140						1.5	4.5
BT40-RSG8-200-M90						200	90	110						1.9	4.8
BT40-RSG8-230-M90						230		140						2.2	4.9
BT40-RSG8-185-M105						185		80						1.6	6.2
BT40-RSG8-215-M105						215	105	110						2.0	6.7
BT40-RSG8-245-M105						245		140						2.3	6.8
BT40-RSG10-125-M25						125		100						1.8	0.4
BT40-RSG10-155-M25						155	25	130						2.2	0.5
BT40-RSG10-185-M25						185		160						2.4	0.7
BT40-RSG10-150-M50						150		100						1.9	0.8
BT40-RSG10-180-M50						180	50	130						2.3	1.0
BT40-RSG10-210-M50						210		160						2.5	1.2
BT40-RSG10-175-M75						175		100						2.0	1.6
BT40-RSG10-205-M75	M10	10.5	22	6.5	19	205	75	130	36	38				2.4	1.8
BT40-RSG10-235-M75						235		160						2.6	2.0
BT40-RSG10-200-M100						200		100						2.0	2.7
BT40-RSG10-230-M100						230	100	130						2.4	3.0
BT40-RSG10-260-M100						260		160						2.6	3.3
BT40-RSG10-220-M120						220		100						2.1	4.0
BT40-RSG10-250-M120						250	120	130						2.5	4.3
BT40-RSG10-280-M120						280		160						2.7	4.6
BT40-RSG12-125-M25						125		100						2.0	0.3
BT40-RSG12-155-M25						155	25	130						2.4	0.4
BT40-RSG12-185-M25						185		160						2.7	0.5
BT40-RSG12-150-M50						150		100						2.1	0.5
BT40-RSG12-180-M50						180	50	130						2.5	0.7
BT40-RSG12-210-M50						210		160						2.8	0.9
BT40-RSG12-175-M75						175		100						2.3	0.9
BT40-RSG12-205-M75	M12	12.5	22	6	24	205	75	130	43	45				2.7	1.1
BT40-RSG12-235-M75						235		160						3.0	1.3
BT40-RSG12-200-M100						200		100						2.4	1.4
BT40-RSG12-230-M100						230	100	130						2.8	1.6
BT40-RSG12-260-M100						260		160						3.1	1.9
BT40-RSG12-225-M125						225		100						2.6	2.1
BT40-RSG12-255-M125						255	125	130						3.0	2.4
BT40-RSG12-285-M125						285		160						3.3	2.8
BT40-RSG16-125-M25						125	25							2.6	0.2
BT40-RSG16-150-M50						150	50							2.8	0.3
BT40-RSG16-175-M75	M16	17	25	6	29	175	75	100	52	54				3.0	0.5
BT40-RSG16-200-M100						200		100						3.2	0.8
BT40-RSG16-225-M125 ※						225	125							3.4	1.2
BT50-RSG8-120-M25						120		95						4.0	0.6
BT50-RSG8-150-M25						150	25	125						4.3	0.7
BT50-RSG8-180-M25						180		155						4.8	0.7
BT50-RSG8-145-M50						145		95						4.0	1.5
BT50-RSG8-175-M50						175	50	125						4.3	1.7
BT50-RSG8-205-M50						205		155						4.8	1.7
BT50-RSG8-170-M75						170		95						4.1	3.1
BT50-RSG8-200-M75	M8	8.5	18	6.5	15	200	75	125	30	32				4.4	3.4
BT50-RSG8-230-M75						230		155						4.9	3.4
BT50-RSG8-185-M90						185		155						4.9	4.4
BT50-RSG8-215-M90						215	90	125						4.4	4.8
BT50-RSG8-245-M90						245		155						4.9	4.8
BT50-RSG8-200-M105						200		95						4.2	6.2
BT50-RSG8-230-M105						230	105	125						4.5	6.6
BT50-RSG8-260-M105						260		155						5.0	6.6
BT50-RSG10-140-M25						140	25	115						4.3	0.4
BT50-RSG10-170-M25	M10	10.5	22	6.5	19	170	25	145	36	38				4.6	0.5
BT50-RSG10-200-M25						200		175						5.6	0.5
BT50-RSG10-165-M50						165		115						4.4	0.8
BT50-RSG10-195-M50						195	50	145						4.7	0.9
BT50-RSG10-225-M50						225		175						5.7	1.0
BT50-RSG10-190-M75						190		115						4.5	1.6
BT50-RSG10-220-M75						220	75	145						4.8	1.7
BT50-RSG10-250-M75						250		175						5.8	1.8
BT50-RSG10-215-M100						215		115						4.5	2.7
BT50-RSG10-245-M100	M10	10.5	22	6.5	19	245	100	145	36	38				4.8	2.9
BT50-RSG10-275-M100						275		175						5.8	2.9
BT50-RSG10-235-M120						235		115						4.6	3.9
BT50-RSG10-265-M120						265	120	145						4.9	4.2
BT50-RSG10-295-M120						295		175						5.9	4.2
BT50-RSG10-255-M140						255		115						4.7	5.5
BT50-RSG10-285-M140						285	140	145						5.0	5.8
BT50-RSG10-315-M140						315		175						6.0	5.8
BT50-RSG12-140-M25						140		115						4.6	0.2
BT50-RSG12-170-M25						170	25	145						5.0	0.3
BT50-RSG12-200-M25						200		175						5.8	0.4
BT50-RSG12-165-M50						165		115						4.7	0.5
BT50-RSG12-195-M50						195	50	145						5.1	0.6
BT50-RSG12-225-M50						225		175						5.9	0.6
BT50-RSG12-190-M75						190		115						4.9	0.8
BT50-RSG12-220-M75						220	75	145						5.3	1.0
BT50-RSG12-250-M75						250		175						6.1	1.0
BT50-RSG12-215-M100						215		115						5.0	1.3
BT50-RSG12-245-M100	M12	12.5	22	6	24	245	100	145	43	45				5.4	1.5
BT50-RSG12-275-M100						275		175						6.2</	

標準切削条件表

Recommended Cutting Conditions

肩削り加工条件 Cutting conditions for shoulder milling

- 切込み深さ l_a までは完全2枚刃です。
- l_a を超えると、オーバーラップの関係により、1枚刃領域が発生します。切込み深さと送り速度の関係に注意して下さい。
- 一般的に切込み境界部はインサートの損傷が大きくなる傾向にあります。
深切込みでご使用の際は、切込み境界部が2枚刃になる切込み量を推奨します。

- Full 2 inserts are used up to the cutting depth l_a .
- If l_a is exceeded, depending on the overlap relationship, a single insert region may occur. Care should be taken regarding the relationship between cutting depth and feed rate.
- In general, insert damage tends to become larger at the border region of the cut. When using for deep cutting, it is recommended that the cutting depth be set so that two inserts will be used at the cutting border region.

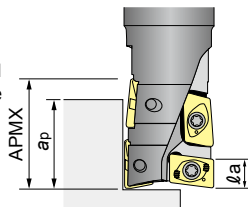

工具径DC Tool dia.	推奨切込み量 a_p Recommended a_p		最大切込み量 APMX
	完全2枚刃領域 l_a Full 2 inserts region		
$\phi 16, \phi 17$	~4.5	13~16	19
$\phi 20, \phi 21$	~5.5	15~18	23
$\phi 25, \phi 26$	~7.0	18~24	29
$\phi 32, \phi 33$	~8.5	21~28	34
$\phi 40$	~7.0	21~23	42
$\phi 50$	~8.5	24~28	50

※赤字は第一推奨材種です。 ※Red indicates primary recommended grade.

被削材 Work material	推奨材種 Recommended grade	切削速度 v_c (m/min) Cutting speed	工具径DC Tool dia.(mm)							
			$\phi 16, \phi 17$				$\phi 20, \phi 21$			
			切込み深さ a_p (mm) Cutting Depth	切込み幅 a_e (mm) Cutting Width	送り速度 V_f (mm/min) Feed	1刃当りの送り f_z (mm/t) Feed rate	切込み深さ a_p (mm) Cutting Depth	切込み幅 a_e (mm) Cutting Width	送り速度 V_f (mm/min) Feed	1刃当りの送り f_z (mm/t) Feed rate
一般構造用鋼 Steels for general structure SS(≤ 180 HB)	※ JS4060 JS4045 PTH30E	180 (140~220)	~4.5	~8	570	0.08	~5.5	~10	860	0.15
			4.5~13	~3	500	0.07	5.5~15	~6	690	0.12
			13~19	~2	290	0.04	15~23	~3	460	0.08
			回転数 $n=3,580\text{min}^{-1}$ ($v_c=180\text{m/min}$)				回転数 $n=2,870\text{min}^{-1}$ ($v_c=180\text{m/min}$)			
炭素鋼・合金鋼 Carbon Steels & Alloy Steels S-C SCM (180~300HB)	JS4060 JS4045	160 (120~200)	~4.5	~8	510	0.08	~5.5	~10	760	0.15
			4.5~13	~3	450	0.07	5.5~15	~6	610	0.12
			13~19	~2	250	0.04	15~23	~3	410	0.08
			回転数 $n=3,180\text{min}^{-1}$ ($v_c=160\text{m/min}$)				回転数 $n=2,550\text{min}^{-1}$ ($v_c=160\text{m/min}$)			
炭素鋼・合金鋼 Carbon Steels & Alloy Steels S-C SCM (30~40HRC)	JP4120	100 (70~120)	~4.5	~6	320	0.08	~5.5	~6	320	0.10
			4.5~13	~2	280	0.07	5.5~15	~4	260	0.08
			13~19	~1	160	0.04	15~23	~2	190	0.06
			回転数 $n=1,990\text{min}^{-1}$ ($v_c=100\text{m/min}$)				回転数 $n=1,590\text{min}^{-1}$ ($v_c=100\text{m/min}$)			
ステンレス鋼 Stainless Steels SUS	Dry JS4045	250 (200~300)	~4.5	~8	800	0.08	~5.5	~10	1,200	0.15
			4.5~13	~3	700	0.07	5.5~15	~6	960	0.12
			13~19	~2	400	0.04	15~23	~3	640	0.08
	回転数 $n=4,970\text{min}^{-1}$ ($v_c=250\text{m/min}$)				回転数 $n=3,980\text{min}^{-1}$ ($v_c=250\text{m/min}$)					
	Wet PTH30E	100 (80~120)	~4.5	~8	320	0.08	~5.5	~10	480	0.15
			4.5~13	~3	280	0.07	5.5~15	~6	380	0.12
13~19			~2	160	0.04	15~23	~3	260	0.08	
回転数 $n=1,990\text{min}^{-1}$ ($v_c=100\text{m/min}$)				回転数 $n=1,590\text{min}^{-1}$ ($v_c=100\text{m/min}$)						
鋳鉄 Cast Irons FC FCD	PTH13S	160 (120~200)	~4.5	~8	640	0.10	~5.5	~10	760	0.15
			4.5~13	~4	450	0.07	5.5~15	~7	610	0.12
			13~19	~3	260	0.04	15~23	~4	410	0.08
			回転数 $n=3,180\text{min}^{-1}$ ($v_c=160\text{m/min}$)				回転数 $n=2,550\text{min}^{-1}$ ($v_c=160\text{m/min}$)			

【注意】(1)短刃長形は切込み深さに注意して下さい。
(2)JSコーティングは通電式タッチセンサーに反応しませんのでご注意ください。

● 工具突出し量が多い場合は、びびり振動などが発生しやすく、不安定な切削状態になりがちです。異常損傷、短寿命の原因となりますので右表の係数を参考にして下の条件表の切込み幅 a_e を小さくして加工して下さい。

● モジュラー超硬シャンクにて5DC以上の突き出し長さでご使用される場合、切削速度 v_c に0.7~0.5の係数を掛けて条件設定をして下さい。

• When the amount the tool sticks out is large, chattering vibrations, etc. are more likely to occur, making cutting conditions unstable. Since this may result in abnormal damage and cause shortened tool life, refer to the factors in the table at right and reduce the cutting width a_e when machining.

• When using a modular carbide shank with a tool overhang of 5DC or more, set the conditions by multiplying cutting speed v_c by a factor of 0.7 to 0.5.

DC: 工具径 Tool dia. (mm)

工具径DC Tool dia.	工具突出し長さ Overhang		
	DC×2	DC×3	DC×4
φ16, φ17	$a_e \times 1$	$a_e \times 0.6$	$a_e \times 0.3$
φ20, φ21	$a_e \times 1$	$a_e \times 0.8$	$a_e \times 0.6$
φ25, φ26	$a_e \times 1$	$a_e \times 1$	$a_e \times 0.7$
φ32, φ33	$a_e \times 1$	$a_e \times 1$	$a_e \times 0.8$
φ40	$a_e \times 1$	$a_e \times 1$	$a_e \times 0.8$
φ50	$a_e \times 1$	$a_e \times 1$	$a_e \times 0.8$

工具径DC Tool dia. (mm)																被削材 Work material
φ25, φ26				φ32, φ33				φ40				φ50				
切込み深さ a_p (mm) Cutting Depth	切込み幅 a_e (mm) Cutting Width	送り速度 V_f (mm/min) Feed	1刃当りの送り f_z (mm/t) Feed rate	切込み深さ a_p (mm) Cutting Depth	切込み幅 a_e (mm) Cutting Width	送り速度 V_f (mm/min) Feed	1刃当りの送り f_z (mm/t) Feed rate	切込み深さ a_p (mm) Cutting Depth	切込み幅 a_e (mm) Cutting Width	送り速度 V_f (mm/min) Feed	1刃当りの送り f_z (mm/t) Feed rate	切込み深さ a_p (mm) Cutting Depth	切込み幅 a_e (mm) Cutting Width	送り速度 V_f (mm/min) Feed	1刃当りの送り f_z (mm/t) Feed rate	
~7	~12.5	780	0.17	~8.5	~16	720	0.20	~7	~20	490	0.17	~8.5	~25	460	0.20	一般構造用鋼 Steels for general structure SS(≤180HB)
7~18	~7	600	0.13	8.5~21	~10	540	0.15	7~21	~12	370	0.13	8.5~24	~15	350	0.15	
18~29	~4	460	0.10	21~34	~5	430	0.12	21~42	~8	290	0.10	24~50	~10	280	0.12	
回転数 $n=2,290\text{min}^{-1}$ ($v_c=180\text{m/min}$)				回転数 $n=1,790\text{min}^{-1}$ ($v_c=180\text{m/min}$)				回転数 $n=1,430\text{min}^{-1}$ ($v_c=180\text{m/min}$)				回転数 $n=1,150\text{min}^{-1}$ ($v_c=180\text{m/min}$)				
~7	~12.5	700	0.17	~8.5	~16	640	0.20	~7	~20	430	0.17	~8.5	~25	410	0.20	炭素鋼・合金鋼 Carbon Steels & Alloy Steels S-C SCM (180~300HB)
7~18	~7	530	0.13	8.5~21	~10	480	0.15	7~21	~12	330	0.13	8.5~24	~15	310	0.15	
18~29	~4	410	0.10	21~34	~5	380	0.12	21~42	~8	250	0.10	24~50	~10	250	0.12	
回転数 $n=2,040\text{min}^{-1}$ ($v_c=160\text{m/min}$)				回転数 $n=1,590\text{min}^{-1}$ ($v_c=160\text{m/min}$)				回転数 $n=1,270\text{min}^{-1}$ ($v_c=160\text{m/min}$)				回転数 $n=1,020\text{min}^{-1}$ ($v_c=160\text{m/min}$)				
~7	~8	310	0.12	~8.5	~10	300	0.15	~7	~20	190	0.12	~8.5	~25	190	0.15	炭素鋼・合金鋼 Carbon Steels & Alloy Steels S-C SCM (30~40HRC)
7~18	~6	260	0.10	8.5~21	~7	240	0.12	7~21	~12	160	0.10	8.5~24	~15	150	0.12	
18~29	~3	200	0.08	21~34	~4	200	0.10	21~42	~8	130	0.08	24~50	~10	130	0.10	
回転数 $n=1,270\text{min}^{-1}$ ($v_c=100\text{m/min}$)				回転数 $n=1,000\text{min}^{-1}$ ($v_c=100\text{m/min}$)				回転数 $n=800\text{min}^{-1}$ ($v_c=100\text{m/min}$)				回転数 $n=640\text{min}^{-1}$ ($v_c=100\text{m/min}$)				
~7	~12.5	1,080	0.17	~8.5	~16	1,000	0.20	~7	~20	680	0.17	~8.5	~25	640	0.20	ステンレス鋼 Stainless Steels SUS
7~18	~7	830	0.13	8.5~21	~10	750	0.15	7~21	~12	520	0.13	8.5~24	~15	480	0.15	
18~29	~4	640	0.10	21~34	~5	600	0.12	21~42	~8	400	0.10	24~50	~10	380	0.12	
回転数 $n=3,180\text{min}^{-1}$ ($v_c=250\text{m/min}$)				回転数 $n=2,490\text{min}^{-1}$ ($v_c=250\text{m/min}$)				回転数 $n=1,990\text{min}^{-1}$ ($v_c=250\text{m/min}$)				回転数 $n=1,590\text{min}^{-1}$ ($v_c=250\text{m/min}$)				
~7	~12.5	430	0.17	~8.5	~16	400	0.20	~7	~20	270	0.17	~8.5	~25	260	0.20	鋳鉄 Cast Irons FC FCD
7~18	~7	330	0.13	8.5~21	~10	300	0.15	7~21	~12	210	0.13	8.5~24	~15	190	0.15	
18~29	~4	260	0.10	21~34	~5	240	0.12	21~42	~8	160	0.10	24~50	~10	150	0.12	
回転数 $n=1,270\text{min}^{-1}$ ($v_c=100\text{m/min}$)				回転数 $n=1,000\text{min}^{-1}$ ($v_c=100\text{m/min}$)				回転数 $n=800\text{min}^{-1}$ ($v_c=100\text{m/min}$)				回転数 $n=640\text{min}^{-1}$ ($v_c=100\text{m/min}$)				
~7	~12.5	690	0.17	~8.5	~16	640	0.20	~7	~20	430	0.17	~8.5	~25	410	0.20	鋳鉄 Cast Irons FC FCD
7~18	~8	530	0.13	8.5~21	~11	480	0.15	7~21	~12	330	0.13	8.5~24	~15	310	0.15	
18~29	~5	410	0.10	21~34	~6	380	0.12	21~42	~8	250	0.10	24~50	~10	250	0.12	
回転数 $n=2,040\text{min}^{-1}$ ($v_c=160\text{m/min}$)				回転数 $n=1,590\text{min}^{-1}$ ($v_c=160\text{m/min}$)				回転数 $n=1,270\text{min}^{-1}$ ($v_c=160\text{m/min}$)				回転数 $n=1,020\text{min}^{-1}$ ($v_c=160\text{m/min}$)				

[Note] (1) For short flute type, use extra caution regarding the cutting depth.
 (2) Please note that the JS Coating does not cause a reaction in conductive touch sensors.

標準切削条件表

Recommended Cutting Conditions

○ 溝削り加工条件 Cutting condition for slotting.

● 肩削り加工条件を参考に、送り速度は70%を目安として下さい。

● 切込み深さは完全2枚刃領域 ℓa での切削を推奨します。

- Refer to the cutting conditions for shoulder milling and set the feed rate to 70% of the value as general criteria.
- It is recommended that the cutting depth be set within the full 2 inserts region ℓa .

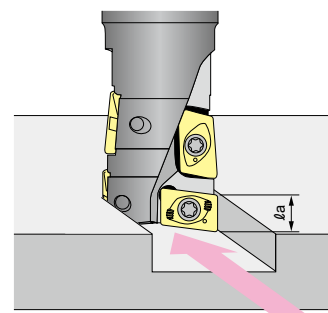

○ 傾斜加工条件 Cutting condition for ramping

● 肩削り加工条件を参考に送り速度は、70%を目安として下さい。

● 鋼切削時の傾斜角度 θ は3°以下を推奨します。

これをこえると切りくずが分断されず、工具本体にからみつく場合があります危険です。

● 40HRC以上の傾斜角度は1°以下に設定して下さい。

- Refer to the cutting conditions for shoulder milling and set the feed rate to 70% of the value as general criteria.
- When cutting steel, it is recommended that the ramp angle θ is 3° or less. With angles larger than this there is a danger of the cut chips not breaking off and sticking to the tool body.
- For hardnesses higher than 40HRC, the ramp angle should be set to 1° or less.

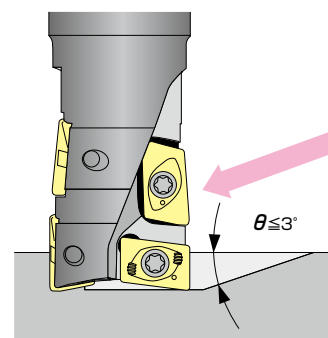

○ ドリル加工条件 Cutting condition for drilling

● 穴加工深さは工具径の半分以下にてご使用下さい。また、40HRC以上の穴加工には、ヘリカル穴あけを適用して下さい。

● 切りくず分断のためステップ送りを行って下さい。

● 切りくず除去のため、エアブローを使用しながら加工して下さい。

● 切りくずが思わぬ方向へ飛び散る場合がありますので、適切な安全策を施してご使用下さい。

● 外径 $\phi 17, 21, 26, 33$ のAHJM, AHJL, AHJL-RSは、穴中心部に $\phi 1$ 程度の柱が残ります。

※赤字は第一推奨材種です。
Red indicates primary recommended grade.

被削材 Work material	推奨材種 Recommended grade	切削速度 V_c (m/min) Cutting speed	工具径DC Tool dia.(mm)							
			$\phi 16, \phi 17$		$\phi 20, \phi 21$		$\phi 25, \phi 26$			
			送り Feed (mm/min)	ステップ Step (mm)	送り Feed (mm/min)	ステップ Step (mm)	送り Feed (mm/min)	ステップ Step (mm)		
一般構造用鋼 Steels for general structure SS($\leq 180\text{HB}$)	※ JS4060 JS4045 PTH30E	180 (140~220)	110	0.2	120	0.3	120	0.3	120	0.3
炭素鋼・合金鋼 Carbon Steels & Alloy Steels S-C SCM(180~300HB)	JS4060 JS4045	160 (120~200)	100	0.2	100	0.3	100	0.3	100	0.3
炭素鋼・合金鋼 Carbon Steels & Alloy Steels S-C SCM(30~40HRC)	JP4120	100 (70~120)	40	0.15	50	0.25	50	0.25	50	0.25
ステンレス鋼 Stainless Steels SUS	JS4045 PTH30E	100 (80~120)	60	0.15	60	0.25	60	0.25	60	0.25
鋳鉄 Cast Irons FC FCD	PTH13S	160 (120~200)	130	0.3	130	0.5	120	0.5	120	0.5

- 【注意】 (1) 切削の条件は上記表を参考に、加工時の状況に合わせて調整して下さい。
(2) JSコーティングは通電式タッチセンサーに反応しませんのでご注意ください。
(3) インサート交換は早めに行い、過度の使用による破損を防止してください。
(4) 排出した切りくずは飛散し作業者を切傷させ、火傷あるいは目に入って負傷させる恐れがありますので、ご使用に際してはその周囲に安全カバーを取り付け保護めがね等の保護具を着用して、安全な環境で作業される事をお願い致します。
(5) 不水溶性切削油は、火災の恐れがありますので使用しないで下さい。

- 【Note】 (1) Choose the best cutting condition from above table.
(2) Please note that the JS Coating does not cause a reaction in conductive touch sensors.
(3) In order to avoid of insert breakage, please change insert earlier.
(4) The steel chips may cause cuts, burns or damages to eyes. Be sure to install the safety cover around the tool and wear the safety glasses when carrying out any works.
(5) Please don't use cutting oil as coolant. (It may be cause of fire.)

○ プランジ加工条件 Cutting condition for plunging

- ドリル加工条件を参考に送り速度は、150～180%を目安として下さい。
- ステップ送りは不要です。
- ピックフィード $pf \leq 0.5DC$ 、径方向切込み量 ae は下表を参照して下さい。

- Refer to the cutting conditions for drilling and set feed rate at 150% to 180% as general criteria.
- Step feed is not necessary.
- Pick feed $pf \leq 0.5DC$; Refer to the table below for diametrical cutting amount ae .

工具径DC Tool dia.	$\phi 16, \phi 17$	$\phi 20, \phi 21$	$\phi 25, \phi 26$	$\phi 32, \phi 33$	$\phi 40$	$\phi 50$
径方向切込み量 ae Radial depth of cut	4.5	6	7.5	8.5	7.5	8.5

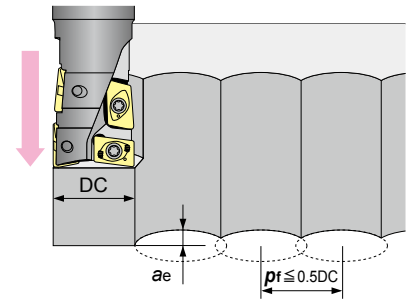

○ ヘリカル穴あけ条件 Cutting condition for helical boring

- 肩削り加工条件を参考に送り速度は、70%を目安として下さい。
- 工具径DCにおけるヘリカル穴径 ϕDH は $1.2DC \sim 1.8DC$ です。
- 切りくず除去のため、エアブローを使用しながら加工して下さい。

- Refer to the cutting conditions for shoulder milling and set the feed rate to 70% of the value as general criteria.
- The helical hole diameter ϕDH for a tool diameter DC is $1.2DC$ to $1.8DC$.
- Boring should be performed while using an air blower to discharge cutting chips.

ヘルカル穴径 Helical hole dia. ϕDt 工具径DC Tool dia. DC

$$\phi Dt = \phi DH - DC$$
 傾斜角 Ramp angle θ

$$P = \pi \times \phi Dt \times \tan \theta$$

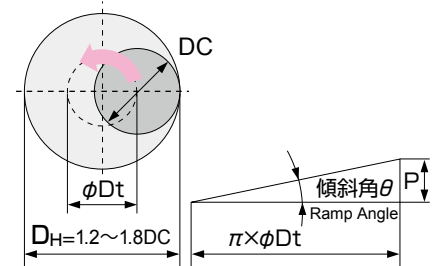

● 工具中心軌跡
Helical centre

● 工具1周当りの切込み量
Cutting amount per tool rotation

- The drill hole depth h should be less than the one half the tool diameter. In addition, for materials with hardnesses of 40HRC or higher, helical boring should be performed.
- To allow the cut chips to break off, step feed should be performed.
- An air blower should be used while machining to remove chips.
- Since the cut chips may fly off in unexpected directions, take appropriate safety measures when machining.
- For AHJM, AHJL, and AHJL-RS with flute diameters of $\phi 17, 21, 26,$ and $33,$ a column with a diameter of about $\phi 1$ will be left in the center of the hole.

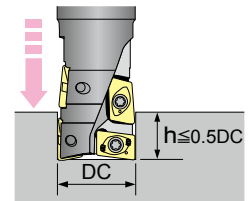

	工具径DC Tool dia.(mm)						被削材 Work material
	$\phi 32, \phi 33$		$\phi 40$		$\phi 50$		
	送り Feed (mm/min)	ステップ Step (mm)	送り Feed (mm/min)	ステップ Step (mm)	送り Feed (mm/min)	ステップ Step (mm)	
	90	0.3	70	0.3	60	0.3	一般構造用鋼 Steels for general structure SS ($\leq 180HB$)
	回転数 $n=1,790\text{min}^{-1}$		回転数 $n=1,430\text{min}^{-1}$		回転数 $n=1,150\text{min}^{-1}$		
	80	0.3	60	0.3	50	0.3	炭素鋼・合金鋼 Carbon Steels & Alloy Steels S-C SCM (180~300HB)
	回転数 $n=1,590\text{min}^{-1}$		回転数 $n=1,270\text{min}^{-1}$		回転数 $n=1,020\text{min}^{-1}$		
	40	0.25	30	0.25	25	0.25	炭素鋼・合金鋼 Carbon Steels & Alloy Steels S-C SCM (30~40HRC)
	回転数 $n=1,000\text{min}^{-1}$		回転数 $n=800\text{min}^{-1}$		回転数 $n=640\text{min}^{-1}$		
	50	0.25	40	0.25	30	0.25	ステンレス鋼 Stainless Steels SUS
	回転数 $n=1,000\text{min}^{-1}$		回転数 $n=800\text{min}^{-1}$		回転数 $n=640\text{min}^{-1}$		
	110	0.5	75	0.5	60	0.5	鋳鉄 Cast Irons FC FCD
	回転数 $n=1,590\text{min}^{-1}$		回転数 $n=1,270\text{min}^{-1}$		回転数 $n=1,020\text{min}^{-1}$		



図、表等のデータは試験結果の一例であり、保証値ではありません。
「MOLDINO」は株式会社MOLDINOの登録商標です。

The diagrams and table data are examples of test results, and are not guaranteed values.
"MOLDINO" is a registered trademark of MOLDINO Tool Engineering, Ltd.

安全上のご注意 Attention on Safety

1. 取扱上のご注意

- (1) 工具をケース(梱包)から取り出す際は、足元への落下あるいは素手の指先へ落ちて怪我をしないように十分ご注意ください。
- (2) インサートをセットして実際にご使用する場合は、切れ刃を素手で直接触れないように注意してください。

2. 取付け時のご注意

- (1) ご使用にあたって、インサートのセッティングは確実に行っていただき、アーク等への取付けも確実に行ってください。
- (2) ご使用中に、異常な振動等が発生した場合は、直ちに機械を停止させて、その振動の原因を除いてください。

3. 使用上のご注意

- (1) 切削工具あるいは被削材の寸法・回転の方向は、あらかじめ確認しておいてください。
- (2) 標準切削条件表の数値は、新しい作業の立上げの目安としてご利用ください。切込みが大きい場合、使用機械の剛性が小さい場合あるいは被加工物の性状に応じて切削条件を適正に調整してご使用ください。
- (3) インサートは硬質の材料です。ご使用中に破損して飛散する場合があります。また、切りくずが飛散することがあります。これらの飛散物等は作業者を切傷させ、火傷あるいは目に入って負傷させる恐れがありますので、工具をご使用中はその周囲に安全カバーを取付け、保護メガネ等の保護具を着用して安全な環境下での作業をお願いいたします。
 - ・引火や爆発の危険のあるところでは使用しないでください。
 - ・不水溶性切削油は、火災の恐れがありますので使用しないでください。
- (4) 工具を本来の目的以外に使用したり、改造したりしないでください。

4. 工具に関して、安全上の問題点・不明の点・その他ご相談がありましたらフリーダイヤル技術相談へお問い合わせください。

1. Attention regarding handling

- (1) When removing the tool from the case (package), be careful not to drop it on your foot or drop it onto the tips of your bare fingers.
- (2) When actually setting the inserts, be careful not to touch the cutting flute directly with your bare hands.

2. Attention regarding mounting

- (1) When preparing for use, be sure that the inserts are firmly mounted in place and that they are firmly mounted on the arbor, etc.
- (2) If abnormal chattering occurs during use, stop the machine immediately and remove the cause of the chattering.

3. Attention during use

- (1) Before use, confirm the dimensions and direction of rotation of the tool and milling work material.
- (2) The numerical values in the standard cutting conditions table should be used as criteria when starting new work. The cutting conditions should be adjusted as appropriate when the cutting depth is large, the rigidity of the machine being used is low, or according to the conditions of the work material.
- (3) The inserts are made of a hard material. During use, they may break and fly off. In addition, cutting chips may also fly off. Since there is a danger of injury to workers, fire, or eye damage from such flying pieces, a safety cover should be installed and safety equipment such as safety glasses should be worn to create a safe environment for work.
 - ・ Do not use where there is a risk of fire or explosion.
 - ・ Do not use non-water-soluble cutting oils. Such oils may result in fire.
- (4) Do not use the tool for any purpose other than that for which it is intended, and do not modify it.

株式会社 MOLDINO

MOLDINO Tool Engineering, Ltd.

本社 〒130-0026 東京都墨田区両国4-31-11(ヒューリック両国ビル8階)
☎ 03-6890-5101 FAX 03-6890-5134
International Sales Dept. ☎ +81-3-6890-5103 FAX +81-3-6890-5128

ホームページ

<http://www.moldino.com>

フリーダイヤル技術相談

☎ 0120-134159

工具選定データベース [TOOL SEARCH]

TOOLSEARCH

検索

営業企画部	☎ 03-6890-5102 FAX03-6890-5134	海外営業部	☎ 03-6890-5103 FAX03-6890-5128
東京営業所	☎ 03-6890-5110 FAX03-6890-5133	静岡営業所	☎ 054-273-0360 FAX054-273-0361
東北営業所	☎ 022-208-5100 FAX022-208-5102	名古屋営業所	☎ 052-687-9150 FAX052-687-9144
新潟営業所	☎ 0258-87-1224 FAX0258-87-1158	大阪営業所	☎ 06-7668-0190 FAX06-7668-0194
東関東営業所	☎ 0294-88-9430 FAX0294-88-9432	中四営業所	☎ 082-536-2001 FAX082-536-2003
長野営業所	☎ 0268-21-3700 FAX0268-21-3711	九州営業所	☎ 092-289-7010 FAX092-289-7012
北関東営業所	☎ 0276-59-6001 FAX0276-59-6005		
神奈川営業所	☎ 046-400-9429 FAX046-400-9435		

ヨーロッパ / MOLDINO Tool Engineering Europe GmbH Itterpark 12, 40724 Hilden, Germany. TEL: +49-(0)2103-24820. FAX: +49-(0)2103-248230
中国 / MOLDINO Tool Engineering (Shanghai) Ltd. Room 2604-2605, Metro Plaza, 555 Loushanguan Road, Changning District, Shanghai, 200051, CHINA TEL: +86-(0)21-3366-3058. FAX: +86-(0)21-3366-3050
アメリカ / MITSUBISHI MATERIALS U.S.A. CORPORATION 41700 Gardenbrook Road, Suite 120, Novi, MI 48375-1320 U.S.A. TEL: +1(248)308-2620. FAX: +1(248)308-2627
メキシコ / MMC METAL DE MEXICO, S.A. DE C.V. Av. La Cañada No.16, Parque Industrial Bernardo Quintana, El Marques, Querétaro, CP 76246, México TEL: +52-442-1926800
ブラジル / MMC METAL DO BRASIL LTDA. Rua Cincinato Braga, 340 13º andar, Bela Vista - CEP 01333-010 São Paulo - SP., Brasil TEL: +55(11)3506-5600 FAX: +55(11)3506-5677
タイ / MMC Hardmetal (Thailand) Co., Ltd. MOLDINO Division 622 Emponium Tower, Floor 22/1-4, Sukhumvit Road, Klong Tan, Klong Toei, Bangkok 10110, Thailand TEL: +66-(0)2-661-8175 FAX: +66-(0)2-661-8176
インド / MMC Hardmetal India Pvt Ltd. H.O.: Prasad Enclave, #118/119, 1st Floor, 2nd Stage, 5th main, BBMP Ward #11, (New #38), Industrial Suburb, Yeshwanthpura, Bengaluru, 560 022, Karnataka, India. Tel: +91-80-2204-3600

店名

掲載価格は2022年10月1日改定後の消費税抜きの単価を表示しております。予告なく、改良・改善のために仕様変更することがあります。
Specifications for the products listed in this catalog are subject to change without notice due to replacement or modification.

VEGETABLE OIL INK ベジタブルインクで印刷しています。
Printed using vegetable oil ink.

Printed in JAPAN

2022-10 (ME)
2010-3:FP