

NEW



高硬度鋼加工用ボールエンドミル

Ball End Mill for Hardened Steel

エポックディープボールエボリューションハード-TH3

Epoch Deep Ball Evolution Hard-TH3

EPDBEH-TH3

焼きばめホルダに適した
ショートシャンクタイプを新発売

RE1.25以下の全サイズ対象
外径実測値ラベル表記をスタート

*New short shank type for shrink-fit tool holders
Introduction of labeling showing actual tool diameter
(for all sizes up to RE1.25)*



株式会社 MOLDINO
MOLDINO Tool Engineering, Ltd.

New Product News No.1701-13 2023-4

新開発した次世代ハードコーティング TH3コーティングを採用 高硬度鋼の加工において 優れた耐摩耗性を発揮

Applies newly developed next-generation hard coating "TH3 Coating"
Excellent wear resistance when machining hardened steel

EPDBEH-TH3の特長 Features of EPDBEH-TH3

- 01** 高硬度鋼加工用TH3コーティング
"TH3 Coating" for hardened steel machining
- 02** 高硬度鋼加工用刃形ダブルフェイス形状
Double-face cutting edge geometry for hardened steel machining
- 03** 高精度加工を追求した工具設計
Tool design to pursue high-accuracy machining



TH3コーティング TH3 Coating						加工用途 Applications		EPDBEH-TH3
炭素鋼 合金鋼 Carbon steel Alloy steel	ステンレス鋼 工具鋼 Stainless steel Tool steel	プリハードン鋼 Pre-hardened steel	焼入れ鋼 45~55HRC Hardened steel 45-55HRC	焼入れ鋼 55~65HRC Hardened steel 55-65HRC	焼入れ鋼 65~72HRC Hardened steel 65-72HRC			

特長 01 高硬度鋼加工用 TH3コーティング Features "TH3 Coating" for hardened steel machining

- 特長及び性能** Features and performance
 - 優れた耐摩耗性・耐熱性を有する高硬度皮膜
 - 優れた耐衝撃性を有し、突発的な欠損を抑制
 - 焼入れ鋼など50HRCを超える高硬度鋼の加工領域において長寿命
 - ・ High hardness coating with excellent wear resistance and heat resistance
 - ・ Has excellent thermal shock resistance enables to suppress sudden chipping
 - ・ Long tool life when cutting high-hardness materials (50HRC or higher) such as hardened steel
- ターゲットとなる鋼種** Target steel grade
 - 焼入れ鋼などの高硬度鋼 (特に50HRC以上)、ハイス鋼
 - ・ Hardened steel (especially 50HRC or higher), high-speed steel

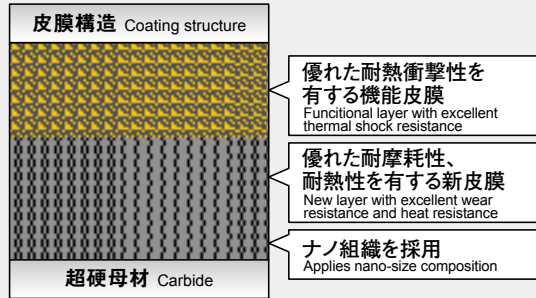

! "TH3"のココがポイント! 新皮膜は"ナノ組織"の適用により、皮膜の破壊単位を小さくする事に成功!

Point New coating achieves to reduce destruction unit of layer by applying "nano-size composition".

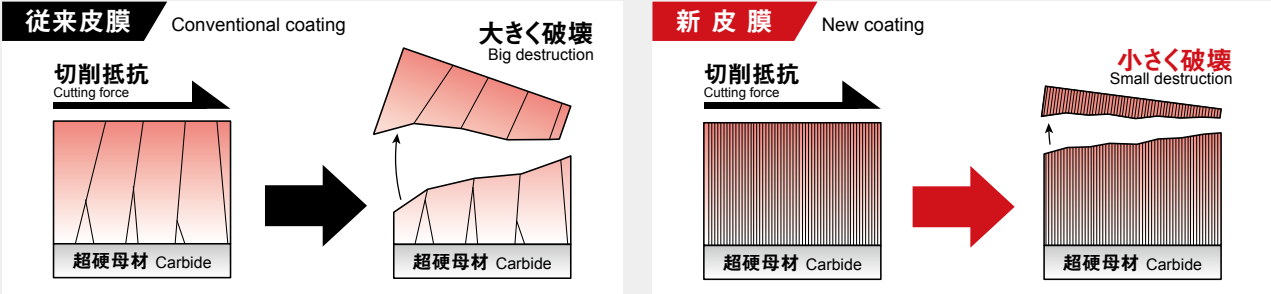



図 ダブルフェイス形状

Figure : Double Face geometry

ボール刃逃げ面を2つの面で形成
Flank of ball area has double face (two-stage flank)

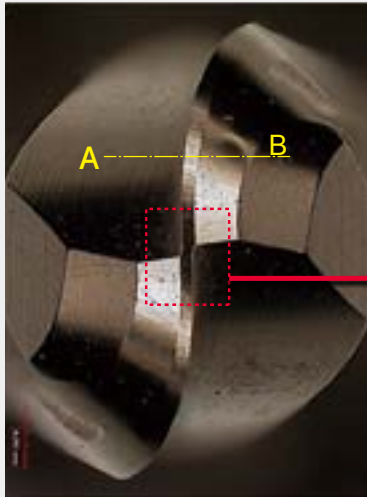
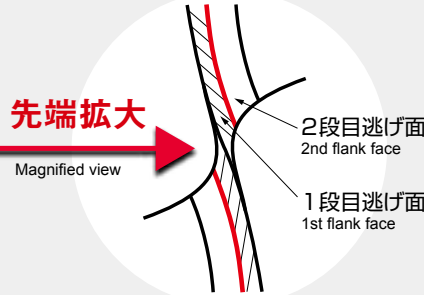

ダブルフェイス形状で工具摩滅を抑制
Double-face effect prevents shape from deteriorating

※RE2以上はダブルフェイス形状ではありません Double face geometry is not applied to RE2 or larger size

図 ボール刃断面概略図(A-B断面)

Figure : A-B cross section view

従来刃形 Conventional geometry



ダブルフェイス形状 Double face geometry

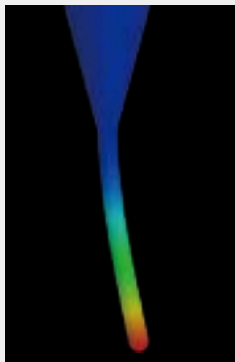
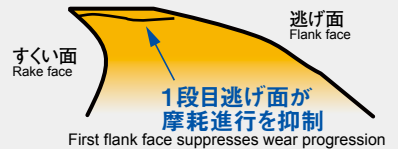

RE0.5-首下長10mmの場合
従来首形状対比10%
のたわみを抑制
(当社計算理論値)

In case of R0.5 - under neck length 10mm,
10% of deflection is suppressed
compared to conventional neck
shape
(Theoretical value by our calculation)

バックドラフト形状 Back draft effect

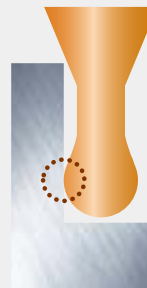

バックドラフトの効果で良好な加工
面品位が得られます。

バックドラフト形状(強バックテーパ)
を継承。点あたりで切削するので
ビビりが低減できます。

Backdraft effect enables good-quality
processed surfaces to be achieved.

Inherits the reliable backdraft shape to enable
chattering to be reduced by performing point
cutting.

○ ポケット立ち壁仕上げ加工評価結果 Evaluation of cutting remain in pocket wall finishing test

図 壁面削り残り量 Figure. Cutting remain amount of wall surface

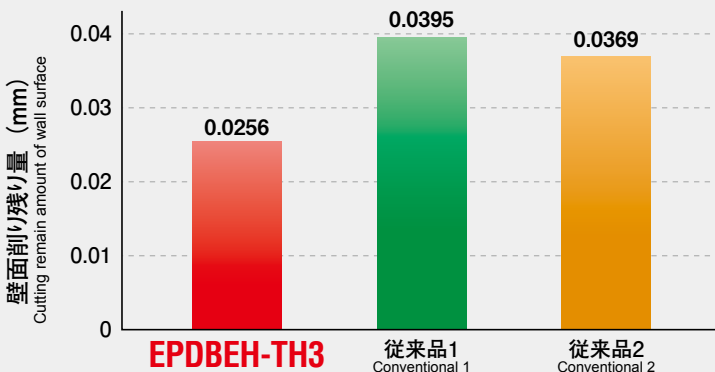

被削材 Work material : YXR33(58HRC)
機械 Machine : 立型MC(HSK-E32) Vertical MC
工具 Tool : EPDBEH2010-6-TH3
切削条件 Cutting conditions : $n=22,600\text{min}^{-1}$
($v_c=71\text{m/min}$)
 $v_f=820\text{mm/min}$
($f_z=0.018\text{mm/t}$)
 $a_p=0.03\text{mm}$ $a_e=0.01\text{mm}$
OH=18mm ミスト Mist

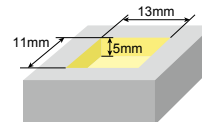

ポケットサイズ Pocket size :
13×11×5mm (立ち壁 Wall)

首部の剛性を高めることでたわみを抑制でき、従来比30%の削り残り量削減
By increasing the neck rigidity, it is possible to suppress deflection and reduce the cutting remain by 30% than conventional design

従来のエポックディープエボリューションシリーズ(EPDBEHやEPDBE)と比較すると
実有効首下長が短くなっております。干渉領域をチェックした上でご使用をお願いします。
Effective neck length is shorter than existing Epoch Deep Evolution series (EPDBEH, EPDBE). Please use with checking interference area.

⇒ 干渉チェックはCAD/CAMサポートデータパックをご使用ください。詳細は弊社ホームページをご覧ください
⇒ Please use CAD/CAM Support Data Pack for checking interference area. For details, please visit our web site.

<http://www.moldino.com/>

最短首下長 ストロングネックタイプ

Shortest neck length, Strong neck type

従来よりも
太く短い
首形状

Thicker and shorter neck
shape than conventional
lineup

ストロングネック
Strong neck

従来品
Conventional

各種精密金型の加工にお役立てください

Please utilize for machining various precision molds and dies



Semiconductor

半導体部品



Light Guide

ライトガイド



Connector

コネクタ



Engraving

文字彫り

さらなる高精度・安定加工の実現に向けて
剛性にこだわった最短首下長をラインナップに追加!

Lineup expanded with shortest under-neck length range that emphasizes rigidity
in order to realize higher precision and stable machining

小径エンドミルは折損のリスクがあるため
首下長がもっと短い工具を使いたい

Needs to use tools with shorter neck length since small diameter end mills have a risk of breakage



最短首下長のストロングネックタイプ

Strong neck type with the shortest neck length

高い工具剛性により安定性・信頼性が向上します
特に工具径が小さくなるほど効果的です

High tool rigidity improves stability and reliability. Especially, it is more effective as the tool diameter becomes smaller.

ショートシャンクタイプ

Short shank type

EPDBEH2○○○F-○○-TH3

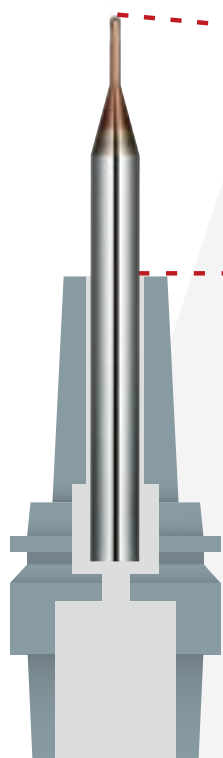

Regular
レギュラーシャンク

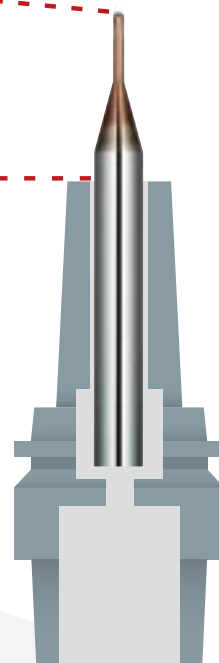

Short
ショートシャンク

待望のショートシャンクタイプが
仲間入り!

Range now includes the short shank type!

【RE0.05～RE1.25 100アイテム items】

焼きばめホルダにFitする全長設計

Full-length design that fits shrink-fit holders

外径実測値ラベル表記をスタート【RE1.25以下の全サイズ対象】

Now featuring labeling of actual tool diameter (for all sizes up to RE1.25)

Actual size indicated here.

ここに実測値 が表記されます。



※商品ラベルイメージ
Example product label

測定の手間なく

実測値をCAMに反映し 加工精度の向上に貢献!!

Allows use of actual size in CAM
without the need for measurement,
for improved machining accuracy!

ショートシャンクタイプから適用いたします。

For initial introduction on short shank type products

ラインナップ

Line Up

ショートシャンクタイプ Short shank type

2枚刃
2 Flutes

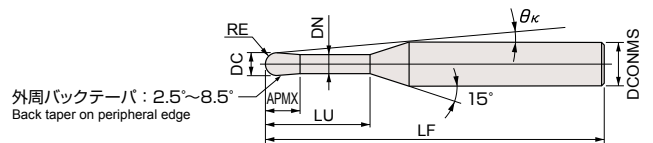

Aタイプ A type

EPDBEH2○○○F-○○○-TH3



ボール半径RE Ball radius	RE公差 Tolerance on RE
0.05~0.25	±0.003
0.3~1.25	±0.005

商品コード Item code	在庫 Stock	寸法 Size(mm)							タイプ Type	干渉角度 Interference angle (°)	勾配角に対する実有効首下長 Effective under neck length with respect to draft angle					希望小売 価格 (円) Suggested retail price (¥)
		ボール半径 Ball radius	外径 Tool dia.	首下長 Under neck length	刃長 Flute length	首径 Neck dia.	全長 Overall length	シャンク径 Shank dia.			0.5°	1°	1.5°	2°	3°	
		RE	DC	LU	APMX	DN	LF	DCONMS			θ_k					
EPDBEH2001F-0.08-TH3	★	0.05	0.1	0.08	0.08	0.08	35	4	B	20.93	-	-	-	-	-	16,290
EPDBEH2001F-0.2-TH3	★			0.2					A	14.64	0.24	0.25	0.25	0.26	0.28	16,290
EPDBEH2001F-0.3-TH3	★			0.3					A	14.46	0.34	0.35	0.36	0.38	0.40	16,720
EPDBEH2001F-0.5-TH3	★			0.5					A	14.10	0.55	0.57	0.59	0.61	0.65	18,110
EPDBEH20015F-0.12-TH3	★	0.075	0.15	0.12	0.12	0.13	35	4	B	15.25	-	-	-	-	-	16,720
EPDBEH20015F-0.3-TH3	★			0.3					A	14.50	0.34	0.35	0.36	0.37	0.40	16,720
EPDBEH20015F-0.5-TH3	★			0.5					A	14.14	0.55	0.56	0.58	0.60	0.65	18,110
EPDBEH20015F-0.75-TH3	★			0.75					A	13.71	0.81	0.83	0.86	0.89	0.96	19,710
EPDBEH2002F-0.15-TH3	★	0.1	0.2	0.15	0.15	0.18	35	4	B	20.23	-	-	-	-	-	11,680
EPDBEH2002F-0.3-TH3	★			0.3					A	14.54	0.34	0.35	0.36	0.37	0.39	11,680
EPDBEH2002F-0.5-TH3	★			0.5					A	14.17	0.55	0.56	0.58	0.60	0.64	11,680
EPDBEH2002F-0.75-TH3	★			0.75					A	13.73	0.81	0.83	0.86	0.89	0.95	11,680
EPDBEH2002F-1-TH3	★			1			38		A	13.32	1.06	1.10	1.13	1.17	1.26	11,680
EPDBEH2003F-0.25-TH3	★	0.15	0.3	0.25	0.25	0.27	35	4	B	14.45	-	-	-	-	-	11,470
EPDBEH2003F-0.5-TH3	★			0.5					A	14.21	0.56	0.58	0.60	0.61	0.65	11,470
EPDBEH2003F-0.75-TH3	★			0.75					A	13.76	0.82	0.85	0.87	0.90	0.96	11,470
EPDBEH2003F-1-TH3	★			1					A	13.33	1.08	1.11	1.15	1.19	1.27	11,470
EPDBEH2003F-1.5-TH3	★			1.5			38		A	12.56	1.60	1.65	1.70	1.76	1.89	12,220
EPDBEH2004F-0.3-TH3	★	0.2	0.4	0.3	0.3	0.37	35	4	B	14.53	-	-	-	-	-	7,810
EPDBEH2004F-0.5-TH3	★			0.5					A	14.28	0.56	0.58	0.59	0.60	0.64	7,810
EPDBEH2004F-0.75-TH3	★			0.75					A	13.81	0.82	0.84	0.87	0.89	0.95	7,810
EPDBEH2004F-1-TH3	★			1					A	13.37	1.08	1.11	1.14	1.18	1.26	7,810
EPDBEH2004F-1.5-TH3	★			1.5			A		12.57	1.60	1.65	1.70	1.75	1.88	7,940	
EPDBEH2004F-2-TH3	★			2			A		11.86	2.11	2.18	2.25	2.33	2.50	8,230	
EPDBEH2004F-2.5-TH3	★			2.5			A		11.23	2.63	2.72	2.81	2.90	3.13	8,500	
EPDBEH2004F-3-TH3	★			3			A		10.65	3.15	3.25	3.36	3.48	3.75	9,060	
EPDBEH2004F-4-TH3	★	4	A	9.67	4.18	4.32	4.47	4.63	4.99	9,760						
EPDBEH2005F-0.35-TH3	★	0.25	0.5	0.35	0.35	0.47	35	4	B	14.10	-	-	-	-	-	7,810
EPDBEH2005F-0.75-TH3	★			0.75					A	13.88	0.82	0.84	0.86	0.88	0.94	7,810
EPDBEH2005F-1-TH3	★			1					A	13.42	1.08	1.11	1.14	1.17	1.25	7,810
EPDBEH2005F-1.5-TH3	★			1.5					A	12.59	1.59	1.64	1.69	1.75	1.87	7,810
EPDBEH2005F-2-TH3	★			2			A		11.86	2.11	2.18	2.25	2.32	2.49	7,810	
EPDBEH2005F-2.5-TH3	★			2.5			A		11.21	2.63	2.71	2.80	2.90	3.11	7,810	
EPDBEH2005F-3-TH3	★			3			A		10.62	3.15	3.25	3.36	3.47	3.73	7,810	
EPDBEH2005F-4-TH3	★			4			A		9.61	4.18	4.32	4.46	4.62	4.98	7,810	
EPDBEH2005F-5-TH3	★	5	A	8.78	5.21	5.39	5.57	5.77	6.22	7,940						
EPDBEH2006F-0.4-TH3	★	0.3	0.6	0.4	0.4	0.57	35	4	B	14.16	-	-	-	-	-	6,740
EPDBEH2006F-0.75-TH3	★			0.75					A	13.94	0.82	0.84	0.86	0.88	0.93	6,740
EPDBEH2006F-1-TH3	★			1					A	13.47	1.08	1.10	1.13	1.17	1.24	6,740
EPDBEH2006F-1.5-TH3	★			1.5					A	12.61	1.59	1.64	1.69	1.74	1.86	6,000
EPDBEH2006F-2-TH3	★			2			A		11.86	2.11	2.17	2.24	2.31	2.48	6,000	
EPDBEH2006F-2.5-TH3	★			2.5			A		11.19	2.63	2.71	2.80	2.89	3.10	6,140	
EPDBEH2006F-3-TH3	★			3			A		10.59	3.14	3.24	3.35	3.46	3.72	6,140	
EPDBEH2006F-3.5-TH3	★			3.5			A		10.05	3.66	3.78	3.90	4.04	4.34	6,410	
EPDBEH2006F-4-TH3	★			4			A		9.56	4.18	4.31	4.46	4.61	4.97	6,410	
EPDBEH2006F-5-TH3	★			5			A		8.71	5.21	5.38	5.57	5.76	6.21	6,410	
EPDBEH2006F-6-TH3	★	6	A	8.00	6.24	6.45	6.67	6.91	7.45	6,410						
EPDBEH2007F-0.45-TH3	★	0.35	0.7	0.45	0.45	0.67	35	B	14.13	-	-	-	-	-	6,000	
EPDBEH2007F-2-TH3	★			2			A	11.85	2.11	2.17	2.24	2.31	2.47	6,000		
EPDBEH2007F-4-TH3	★			4			A	9.50	4.18	4.31	4.45	4.61	4.95	6,410		

★：新商品の標準在庫品です。★：Stocked items of new products.

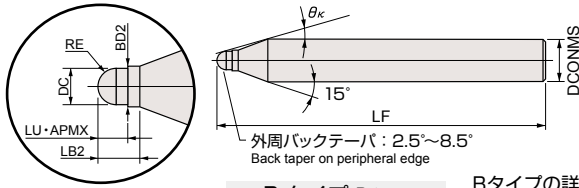

Bタイプ B type

Bタイプの詳細はP.13をご確認ください
For details of B type, refer to page 13.

EPDBEH2000F-0000-TH3

商品コード Item code	在庫 Stock	寸法 Size(mm)							タイプ Type	干渉角度 Interference angle (°)	勾配角に対する実有効首下長 Effective under neck length with respect to draft angle					希望小売 価格(円) Suggested retail price (¥)						
		ボール半径 Ball radius	外径 Tool dia.	首下長 Under neck length	刃長 Flute length	首径 Neck dia.	全長 Overall length	シャンク径 Shank dia.														
		RE	DC	LU	APMX	DN	LF	DCONMS			θ_K	0.5°	1°	1.5°	2°		3°					
EPDBEH2008F-0.5-TH3	★	0.4	0.8	0.5	0.5	0.77	35	4	B	14.20	-	-	-	-	-	6,000						
EPDBEH2008F-1-TH3	★			1					A	13.58	1.07	1.10	1.12	1.15	1.21	6,000						
EPDBEH2008F-1.5-TH3	★			1.5					A	12.66	1.59	1.63	1.68	1.73	1.83	6,000						
EPDBEH2008F-2-TH3	★			2					A	11.85	2.11	2.17	2.23	2.30	2.46	6,000						
EPDBEH2008F-2.5-TH3	★			2.5					A	11.14	2.62	2.70	2.79	2.88	3.08	6,220						
EPDBEH2008F-3-TH3	★			3					A	10.51	3.14	3.24	3.34	3.45	3.70	6,410						
EPDBEH2008F-4-TH3	★			4					A	9.44	4.17	4.31	4.45	4.60	4.94	6,410						
EPDBEH2008F-5-TH3	★			5					A	8.57	5.21	5.38	5.56	5.75	6.19	6,410						
EPDBEH2008F-6-TH3	★			6					A	7.84	6.24	6.45	6.66	6.90	7.43	6,410						
EPDBEH2008F-8-TH3	★			8					A	6.70	8.31	8.58	8.88	9.20	9.92	6,410						
EPDBEH2009F-0.6-TH3	★	0.45	0.9	0.6	0.6	0.87	35	4	B	13.84	-	-	-	-	-	6,000						
EPDBEH2009F-2-TH3	★			2					A	11.85	2.11	2.16	2.23	2.29	2.44	6,000						
EPDBEH2009F-4-TH3	★			4					A	9.38	4.17	4.30	4.44	4.59	4.93	6,410						
EPDBEH2009F-6-TH3	★			6					A	7.75	6.24	6.44	6.66	6.89	7.42	6,410						
EPDBEH2010F-0.8-TH3	★	0.5	1	0.8	0.8	0.96	35	4	B	13.47	-	-	-	-	-	5,020						
EPDBEH2010F-1.5-TH3	★			1.5					A	12.67	1.61	1.64	1.69	1.73	1.83	5,020						
EPDBEH2010F-2-TH3	★			2					A	11.82	2.12	2.18	2.24	2.31	2.46	5,020						
EPDBEH2010F-2.5-TH3	★			2.5					A	11.07	2.64	2.71	2.80	2.88	3.08	5,020						
EPDBEH2010F-3-TH3	★			3					A	10.41	3.16	3.25	3.35	3.46	3.70	5,020						
EPDBEH2010F-4-TH3	★			4					A	9.29	4.19	4.32	4.46	4.61	4.94	5,720						
EPDBEH2010F-5-TH3	★			5					A	8.39	5.22	5.39	5.57	5.76	6.19	5,720						
EPDBEH2010F-6-TH3	★			6					A	7.65	6.26	6.46	6.67	6.91	7.43	6,140						
EPDBEH2010F-7-TH3	★			7					A	7.03	7.29	7.53	7.78	8.06	8.67	6,140						
EPDBEH2010F-8-TH3	★			8					A	6.50	8.32	8.60	8.89	9.21	9.91	6,140						
EPDBEH2010F-10-TH3	★			10					A	5.65	10.39	10.74	11.11	11.51	12.40	6,140						
EPDBEH2010F-12-TH3	★			12					A	5.00	12.46	12.88	13.32	13.81	14.89	6,140						
EPDBEH2015F-2-TH3	★	0.75	1.5	2	1.35	1.45	35	4	A	11.76	2.13	2.18	2.23	2.29	2.42	5,850						
EPDBEH2015F-2.5-TH3	★			2.5					A	10.88	2.65	2.72	2.79	2.87	3.04	5,850						
EPDBEH2015F-3-TH3	★			3					A	10.12	3.17	3.25	3.34	3.44	3.66	5,850						
EPDBEH2015F-4-TH3	★			4					A	8.88	4.20	4.32	4.45	4.59	4.91	5,850						
EPDBEH2015F-5-TH3	★			5					A	7.90	5.23	5.39	5.56	5.74	6.15	5,850						
EPDBEH2015F-6-TH3	★			6					A	7.12	6.27	6.46	6.67	6.89	7.39	5,850						
EPDBEH2015F-8-TH3	★			8					A	5.95	8.34	8.60	8.88	9.19	9.88	6,140						
EPDBEH2015F-10-TH3	★			10					A	5.10	10.40	10.74	11.10	11.49	12.36	6,690						
EPDBEH2015F-12-TH3	★			12					A	4.47	12.47	12.88	13.32	13.79	14.85	7,250						
EPDBEH2020F-2.5-TH3	★			1					2	2.5	1.7	1.94	35	4	A	10.60	2.66	2.72	2.78	2.85	3.01	5,020
EPDBEH2020F-3-TH3	★	3	A		9.72	3.18	3.25	3.34		3.43					3.63	5,020						
EPDBEH2020F-4-TH3	★	4	A		8.32	4.21	4.32	4.45		4.58					4.87	5,020						
EPDBEH2020F-5-TH3	★	5	A		7.27	5.25	5.39	5.55		5.73					6.11	5,720						
EPDBEH2020F-6-TH3	★	6	A		6.46	6.28	6.46	6.66		6.88					7.36	5,720						
EPDBEH2020F-8-TH3	★	8	A		5.27	8.35	8.60	8.88		9.18					9.84	6,140						
EPDBEH2020F-10-TH3	★	10	A		4.46	10.41	10.74	11.10		11.48					12.33	6,140						
EPDBEH2020F-12-TH3	★	12	A		3.86	12.48	12.88	13.31		13.77					14.82	6,140						
EPDBEH2020F-13-TH3	★	13	A		3.62	13.51	13.95	14.42		14.92					16.06	6,140						
EPDBEH2020F-14-TH3	★	14	A		3.40	14.55	15.02	15.53		16.07					17.30	6,140						
EPDBEH2020F-16-TH3	★	16	A		3.04	16.62	17.16	17.75		18.37					19.79	6,140						
EPDBEH2020F-20-TH3	★	20	A		2.51	20.75	21.44	22.18		22.97					干渉なし	6,140						
EPDBEH2025F-6-TH3	★	1.25	2.5		6	2	2.4	38		4					A	5.54	6.35	6.53	6.72	6.92	7.39	7,720
EPDBEH2025F-10-TH3	★				10										A	3.66	10.48	10.81	11.15	11.52	12.36	8,230
EPDBEH2025F-15-TH3	★				15										A	2.57	15.65	16.15	16.69	17.27	干渉なし	8,380

ラインナップ

Line Up

レギュラーシャンクタイプ Regular shank type

2枚刃
2 Flutes



[注意] RE 2mm以上はバックドラフト形状ではありません。
[Note] RE 2mm or larger does not have backdraft shape.

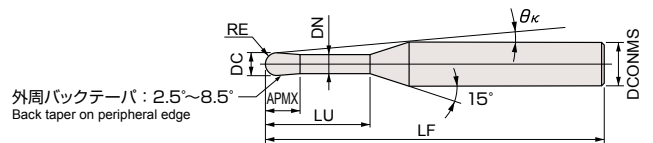

Aタイプ A type

EPDBEH2-○○○-○○○-(S6)-TH3

超硬
Carbide

TH3

Helix angle φ4

h4

h5

ボール半径RE Ball radius	RE公差 Tolerance on RE
0.05~0.25	±0.003
0.3~6	±0.005

商品コード Item code	在庫 Stock	寸法 Size(mm)						タイプ Type	干渉角度 Interference angle (°)	勾配角に対する実有効首下長 Effective under neck length with respect to draft angle					希望小売 価格 (円) Suggested retail price (¥)	
		ボール半径 RE	外径 DC	首下長 LU	刃長 APMX	首径 DN	全長 LF			シャンク径 DCONMS	θk	0.5°	1°	1.5°		2°
EPDBEH2001-0.08-TH3	●	0.05	0.1	0.08	0.08	0.08	45	4	B	20.93	-	-	-	-	16,290	
EPDBEH2001-0.2-TH3	●			0.2					A	14.64	0.24	0.25	0.25	0.26	0.28	16,290
EPDBEH2001-0.3-TH3	●			0.3					A	14.46	0.34	0.35	0.36	0.38	0.40	16,720
EPDBEH2001-0.5-TH3	●			0.5					A	14.10	0.55	0.57	0.59	0.61	0.65	18,110
EPDBEH20015-0.12-TH3	●	0.075	0.15	0.12	0.12	0.13	45	4	B	15.25	-	-	-	-	16,720	
EPDBEH20015-0.3-TH3	●			0.3					A	14.50	0.34	0.35	0.36	0.37	0.40	16,720
EPDBEH20015-0.5-TH3	●			0.5					A	14.14	0.55	0.56	0.58	0.60	0.65	18,110
EPDBEH20015-0.75-TH3	●			0.75					A	13.71	0.81	0.83	0.86	0.89	0.96	19,710
EPDBEH20015-1-TH3	●	0.1	0.2	1	0.15	0.18	50	4	A	13.30	1.06	1.10	1.14	1.18	1.27	19,710
EPDBEH2002-0.15-TH3	●			0.15					B	20.23	-	-	-	-	-	11,680
EPDBEH2002-0.3-TH3	●			0.3					A	14.54	0.34	0.35	0.36	0.37	0.39	11,680
EPDBEH2002-0.5-TH3	●			0.5					A	14.17	0.55	0.56	0.58	0.60	0.64	11,680
EPDBEH2002-0.75-TH3	●			0.75					A	13.73	0.81	0.83	0.86	0.89	0.95	11,680
EPDBEH2002-1-TH3	●			1					A	13.32	1.06	1.10	1.13	1.17	1.26	11,680
EPDBEH2002-1.25-TH3	●			1.25					A	12.93	1.32	1.37	1.41	1.46	1.57	12,650
EPDBEH2002-1.5-TH3	●			1.5					A	12.56	1.58	1.63	1.69	1.75	1.88	12,650
EPDBEH2002-2-TH3	●			2					A	11.89	2.10	2.17	2.24	2.32	2.50	13,930
EPDBEH2002-2.5-TH3	●			2.5					A	11.28	2.61	2.70	2.80	2.90	3.13	15,220
EPDBEH2002-3-TH3	●	3	A	10.73	3.13	3.24	3.35	3.47	3.75	16,290						
EPDBEH2003-0.25-TH3	●	0.15	0.3	0.25	0.25	0.27	50	4	B	14.45	-	-	-	-	11,470	
EPDBEH2003-0.5-TH3	●			0.5					A	14.21	0.56	0.58	0.60	0.61	0.65	11,470
EPDBEH2003-0.75-TH3	●			0.75					A	13.76	0.82	0.85	0.87	0.90	0.96	11,470
EPDBEH2003-1-TH3	●			1					A	13.33	1.08	1.11	1.15	1.19	1.27	11,470
EPDBEH2003-1.25-TH3	●			1.25					A	12.93	1.34	1.38	1.43	1.47	1.58	12,220
EPDBEH2003-1.5-TH3	●			1.5					A	12.56	1.60	1.65	1.70	1.76	1.89	12,220
EPDBEH2003-2-TH3	●			2					A	11.86	2.12	2.18	2.26	2.34	2.52	12,220
EPDBEH2003-2.5-TH3	●			2.5					A	11.24	2.63	2.72	2.81	2.91	3.14	12,650
EPDBEH2003-3-TH3	●			3					A	10.68	3.15	3.25	3.37	3.49	3.76	12,650
EPDBEH2003-3.5-TH3	●			3.5					A	10.18	3.67	3.79	3.92	4.06	4.38	12,650
EPDBEH2003-4-TH3	●	4	A	9.72	4.18	4.32	4.47	4.64	5.00	12,860						
EPDBEH2004-0.3-TH3	●	0.2	0.4	0.3	0.3	0.37	50	4	B	14.53	-	-	-	-	7,810	
EPDBEH2004-0.5-TH3	●			0.5					A	14.28	0.56	0.58	0.59	0.60	0.64	7,810
EPDBEH2004-0.75-TH3	●			0.75					A	13.81	0.82	0.84	0.87	0.89	0.95	7,810
EPDBEH2004-1-TH3	●			1					A	13.37	1.08	1.11	1.14	1.18	1.26	7,810
EPDBEH2004-1.5-TH3	●			1.5					A	12.57	1.60	1.65	1.70	1.75	1.88	7,940
EPDBEH2004-2-TH3	●			2					A	11.86	2.11	2.18	2.25	2.33	2.50	8,230
EPDBEH2004-2.5-TH3	●			2.5					A	11.23	2.63	2.72	2.81	2.90	3.13	8,500
EPDBEH2004-3-TH3	●			3					A	10.65	3.15	3.25	3.36	3.48	3.75	9,060
EPDBEH2004-3.5-TH3	●			3.5					A	10.14	3.66	3.78	3.91	4.05	4.37	9,760
EPDBEH2004-4-TH3	●			4					A	9.67	4.18	4.32	4.47	4.63	4.99	9,760
EPDBEH2004-4.5-TH3	●	4.5	A	9.24	4.70	4.85	5.02	5.20	5.61	10,320						
EPDBEH2004-5-TH3	●	5	A	8.85	5.21	5.39	5.58	5.78	6.23	10,320						
EPDBEH2005-0.35-TH3	●	0.25	0.5	0.35	0.35	0.47	50	4	B	14.10	-	-	-	-	7,810	
EPDBEH2005-0.75-TH3	●			0.75					A	13.88	0.82	0.84	0.86	0.88	0.94	7,810
EPDBEH2005-1-TH3	●			1					A	13.42	1.08	1.11	1.14	1.17	1.25	7,810
EPDBEH2005-1.5-TH3	●			1.5					A	12.59	1.59	1.64	1.69	1.75	1.87	7,810
EPDBEH2005-2-TH3	●			2					A	11.86	2.11	2.18	2.25	2.32	2.49	7,810

● : 標準在庫品です。 ● : Stocked items.

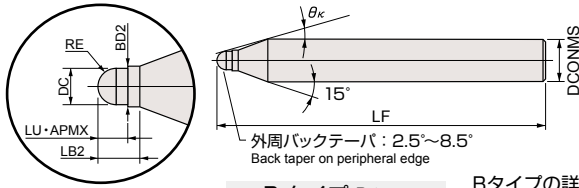

B タイプ B type

Bタイプの詳細はP.13をご確認ください
For details of B type, refer to page 13.

EPDBEH2-○○○-○○○-(S6)-TH3

商品コード Item code	在庫 Stock	寸法 Size(mm)							タイプ Type	干渉角度 Interference angle (°)	勾配角に対する実有効首下長 Effective under neck length with respect to draft angle					希望小売 価格(円) Suggested retail price (¥)	
		ボール半径 Ball radius	外径 Tool dia.	首下長 Under neck length	刃長 Flute length	首径 Neck dia.	全長 Overall length	シャンク径 Shank dia.			θ_k	0.5°	1°	1.5°	2°		3°
		RE	DC	LU	APMX	DN	LF	DCONMS									
EPDBEH2005-2.5-TH3	●	0.25	0.5	2.5	0.35	0.47	50	4	A	11.21	2.63	2.71	2.80	2.90	3.11	7,810	
EPDBEH2005-3-TH3	●			3					A	10.62	3.15	3.25	3.36	3.47	3.73	7,810	
EPDBEH2005-4-TH3	●			4					A	9.61	4.18	4.32	4.46	4.62	4.98	7,810	
EPDBEH2005-5-TH3	●			5					A	8.78	5.21	5.39	5.57	5.77	6.22	7,940	
EPDBEH2005-5.5-TH3	●			5.5					A	8.41	5.73	5.92	6.13	6.35	6.84	8,230	
EPDBEH2005-6-TH3	●			6					A	8.08	6.25	6.46	6.68	6.92	7.46	8,230	
EPDBEH2005-7-TH3	●			7					A	7.48	7.28	7.53	7.79	8.07	8.71	9,760	
EPDBEH2005-8-TH3	●			8					A	6.96	8.31	8.60	8.90	9.22	9.95	9,760	
EPDBEH2006-0.4-TH3	●	0.3	0.6	0.4	0.4	0.57	50	4	B	14.16	-	-	-	-	-	6,740	
EPDBEH2006-0.75-TH3	●			0.75					A	13.94	0.82	0.84	0.86	0.88	0.93	6,740	
EPDBEH2006-1-TH3	●			1					A	13.47	1.08	1.10	1.13	1.17	1.24	6,740	
EPDBEH2006-1.5-TH3	●			1.5					A	12.61	1.59	1.64	1.69	1.74	1.86	6,000	
EPDBEH2006-2-TH3	●			2					A	11.86	2.11	2.17	2.24	2.31	2.48	6,000	
EPDBEH2006-2.5-TH3	●			2.5					A	11.19	2.63	2.71	2.80	2.89	3.10	6,140	
EPDBEH2006-3-TH3	●			3					A	10.59	3.14	3.24	3.35	3.46	3.72	6,140	
EPDBEH2006-3.5-TH3	●			3.5					A	10.05	3.66	3.78	3.90	4.04	4.34	6,410	
EPDBEH2006-4-TH3	●			4					A	9.56	4.18	4.31	4.46	4.61	4.97	6,410	
EPDBEH2006-4.5-TH3	●			4.5					A	9.12	4.69	4.85	5.01	5.19	5.59	6,410	
EPDBEH2006-5-TH3	●			5					A	8.71	5.21	5.38	5.57	5.76	6.21	6,410	
EPDBEH2006-5.5-TH3	●			5.5					A	8.34	5.73	5.92	6.12	6.34	6.83	6,410	
EPDBEH2006-6-TH3	●			6					A	8.00	6.24	6.45	6.67	6.91	7.45	6,410	
EPDBEH2006-7-TH3	●			7					A	7.40	7.28	7.52	7.78	8.06	8.70	7,250	
EPDBEH2006-8-TH3	●			8					A	6.88	8.31	8.59	8.89	9.21	9.94	8,500	
EPDBEH2006-9-TH3	●			9					A	6.43	9.35	9.66	10.00	10.36	11.18	9,060	
EPDBEH2006-10-TH3	●	10	A	6.03	10.38	10.73	11.11	11.51	12.43	8,650							
EPDBEH2006-12-TH3	●	12	A	5.37	12.45	12.87	13.32	13.81	14.91	9,760							
EPDBEH2007-0.45-TH3	●	0.35	0.7	0.45	0.45	0.67	50	4	B	14.13	-	-	-	-	-	6,000	
EPDBEH2007-2-TH3	●			2					A	11.85	2.11	2.17	2.24	2.31	2.47	6,000	
EPDBEH2007-4-TH3	●			4					A	9.50	4.18	4.31	4.45	4.61	4.95	6,410	
EPDBEH2007-6-TH3	●			6					A	7.92	6.24	6.45	6.67	6.91	7.44	6,410	
EPDBEH2007-8-TH3	●			8					A	6.79	8.31	8.59	8.89	9.21	9.93	6,410	
EPDBEH2008-0.5-TH3	●	0.4	0.8	0.5	0.5	0.77	50	4	B	14.20	-	-	-	-	-	6,000	
EPDBEH2008-1-TH3	●			1					A	13.58	1.07	1.10	1.12	1.15	1.21	6,000	
EPDBEH2008-1.5-TH3	●			1.5					A	12.66	1.59	1.63	1.68	1.73	1.83	6,000	
EPDBEH2008-2-TH3	●			2					A	11.85	2.11	2.17	2.23	2.30	2.46	6,000	
EPDBEH2008-2.5-TH3	●			2.5					A	11.14	2.62	2.70	2.79	2.88	3.08	6,220	
EPDBEH2008-3-TH3	●			3					A	10.51	3.14	3.24	3.34	3.45	3.70	6,410	
EPDBEH2008-4-TH3	●			4					A	9.44	4.17	4.31	4.45	4.60	4.94	6,410	
EPDBEH2008-5-TH3	●			5					A	8.57	5.21	5.38	5.56	5.75	6.19	6,410	
EPDBEH2008-6-TH3	●			6					A	7.84	6.24	6.45	6.66	6.90	7.43	6,410	
EPDBEH2008-8-TH3	●			8					A	6.70	8.31	8.58	8.88	9.20	9.92	6,410	
EPDBEH2008-10-TH3	●			10					A	5.85	10.38	10.72	11.10	11.50	12.40	8,500	
EPDBEH2008-12-TH3	●			12					A	5.19	12.44	12.86	13.31	13.80	14.89	10,450	
EPDBEH2009-0.6-TH3	●	0.45	0.9	0.6	0.6	0.87	50	4	B	13.84	-	-	-	-	-	6,000	
EPDBEH2009-2-TH3	●			2					A	11.85	2.11	2.16	2.23	2.29	2.44	6,000	
EPDBEH2009-4-TH3	●			4					A	9.38	4.17	4.30	4.44	4.59	4.93	6,410	
EPDBEH2009-6-TH3	●			6					A	7.75	6.24	6.44	6.66	6.89	7.42	6,410	
EPDBEH2009-8-TH3	●			8					A	6.61	8.31	8.58	8.88	9.19	9.90	6,410	

ラインナップ

Line Up

レギュラーシャンクタイプ Regular shank type

2枚刃
2 Flutes



[注意] RE 2mm以上はバックドラフト形状ではありません。
[Note] RE 2mm or larger does not have backdraft shape.

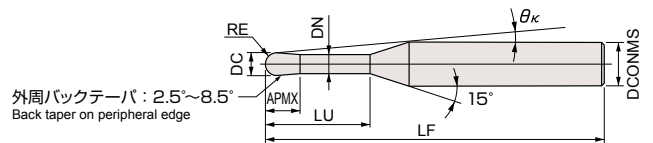

Aタイプ A type

EPDBEH2-○○○-○○○-(S6)-TH3

超硬
Carbide

TH3

Helix angle
φ4

h4

h5

ボール半径RE
Ball radius

0.05~0.25

RE公差
Tolerance on RE

±0.003

0.3~6

±0.005

商品コード Item code	在庫 Stock	寸法 Size(mm)							タイプ Type	干渉角度 Interference angle (°)	勾配角に対する実有効首下長 Effective under neck length with respect to draft angle					希望小売 価格(円) Suggested retail price (¥)
		ボール半径 RE	外径 DC	首下長 LU	刃長 APMX	首径 DN	全長 LF	シャンク径 DCONMS			θ _k	0.5°	1°	1.5°	2°	
EPDBEH2010-0.8-TH3	●	0.5	1	0.8	0.8	0.96	50	4	B	13.47	-	-	-	-	5,020	
EPDBEH2010-1.5-TH3	●			A					12.67	1.61	1.64	1.69	1.73	1.83	5,020	
EPDBEH2010-2-TH3	●			A					11.82	2.12	2.18	2.24	2.31	2.46	5,020	
EPDBEH2010-2.5-TH3	●			A					11.07	2.64	2.71	2.80	2.88	3.08	5,020	
EPDBEH2010-3-TH3	●			A					10.41	3.16	3.25	3.35	3.46	3.70	5,020	
EPDBEH2010-4-TH3	●			A					9.29	4.19	4.32	4.46	4.61	4.94	5,720	
EPDBEH2010-5-TH3	●			A					8.39	5.22	5.39	5.57	5.76	6.19	5,720	
EPDBEH2010-6-TH3	●			A					7.65	6.26	6.46	6.67	6.91	7.43	6,140	
EPDBEH2010-7-TH3	●			A					7.03	7.29	7.53	7.78	8.06	8.67	6,140	
EPDBEH2010-8-TH3	●			A					6.50	8.32	8.60	8.89	9.21	9.91	6,140	
EPDBEH2010-9-TH3	●			A					6.05	9.36	9.67	10.00	10.36	11.16	6,140	
EPDBEH2010-10-TH3	●			A					5.65	10.39	10.74	11.11	11.51	12.40	6,140	
EPDBEH2010-12-TH3	●			A					5.00	12.46	12.88	13.32	13.81	14.89	6,140	
EPDBEH2010-13-TH3	●			A					4.72	13.49	13.95	14.43	14.96	16.13	7,250	
EPDBEH2010-14-TH3	●			A					4.48	14.53	15.02	15.54	16.11	17.37	7,250	
EPDBEH2010-16-TH3	●			A					4.06	16.59	17.16	17.76	18.40	19.86	8,500	
EPDBEH2010-18-TH3	●			A					3.71	18.66	19.29	19.97	20.70	22.35	8,500	
EPDBEH2010-20-TH3	●			A					3.42	20.73	21.43	22.19	23.00	24.83	10,320	
EPDBEH2010-2-S6-TH3	●			A					12.92	2.12	2.18	2.24	2.31	2.46	7,530	
EPDBEH2010-3-S6-TH3	●			A					11.86	3.16	3.25	3.35	3.46	3.70	7,530	
EPDBEH2010-6-S6-TH3	●	A	9.53	6.26	6.46	6.67	6.91	7.43	9,200							
EPDBEH2010-8-S6-TH3	●	A	8.42	8.32	8.60	8.89	9.21	9.91	9,200							
EPDBEH2010-10-S6-TH3	●	A	7.54	10.39	10.74	11.11	11.51	12.40	9,200							
EPDBEH2011-2-TH3	●	0.55	1.1	2	1	1.05	50	4	A	11.78	2.14	2.20	2.26	2.32	2.47	6,740
EPDBEH2011-4-TH3	●			A					9.20	4.21	4.34	4.47	4.62	4.95	7,670	
EPDBEH2011-6-TH3	●			A					7.54	6.28	6.47	6.69	6.92	7.44	8,360	
EPDBEH2011-8-TH3	●			A					6.39	8.34	8.61	8.91	9.22	9.93	8,360	
EPDBEH2011-10-TH3	●			A					5.54	10.41	10.75	11.12	11.52	12.41	8,360	
EPDBEH2012-2-TH3	●	0.6	1.2	2	1.1	1.15	50	4	A	11.78	2.14	2.19	2.25	2.31	2.46	7,670
EPDBEH2012-3-TH3	●			A					10.29	3.17	3.26	3.36	3.46	3.70	7,670	
EPDBEH2012-4-TH3	●			A					9.13	4.21	4.33	4.47	4.61	4.94	7,670	
EPDBEH2012-6-TH3	●			A					7.45	6.27	6.47	6.68	6.91	7.43	8,360	
EPDBEH2012-8-TH3	●			A					6.29	8.34	8.61	8.90	9.21	9.91	8,360	
EPDBEH2012-10-TH3	●			A			5.44	10.41	10.75	11.12	11.51	12.40	8,360			
EPDBEH2012-12-TH3	●			A			4.79	12.48	12.89	13.33	13.81	14.89	8,360			
EPDBEH2012-2-S6-TH3	●			A			12.94	2.14	2.19	2.25	2.31	2.46	11,470			
EPDBEH2012-4-S6-TH3	●			A			10.92	4.21	4.33	4.47	4.61	4.94	11,470			
EPDBEH2014-3-TH3	●			0.7			1.4	3	1.3	1.34	50	4	A	10.15	3.19	3.28
EPDBEH2014-8-TH3	●	A	6.06		8.36	8.62		8.91			9.22		9.91	7,250		
EPDBEH2014-12-TH3	●	A	4.58		12.49	12.90		13.34			13.82		14.89	7,250		
EPDBEH2014-16-TH3	●	A	3.68		16.63	17.18		17.78			18.42		19.86	7,250		
EPDBEH2015-2-TH3	●	0.75	1.5	2	1.35	1.45	50	4	A	11.76	2.13	2.18	2.23	2.29	2.42	5,850
EPDBEH2015-2.5-TH3	●			A					10.88	2.65	2.72	2.79	2.87	3.04	5,850	
EPDBEH2015-3-TH3	●			A					10.12	3.17	3.25	3.34	3.44	3.66	5,850	
EPDBEH2015-4-TH3	●			A					8.88	4.20	4.32	4.45	4.59	4.91	5,850	
EPDBEH2015-5-TH3	●			A					7.90	5.23	5.39	5.56	5.74	6.15	5,850	

● : 標準在庫品です。 ● : Stocked items.

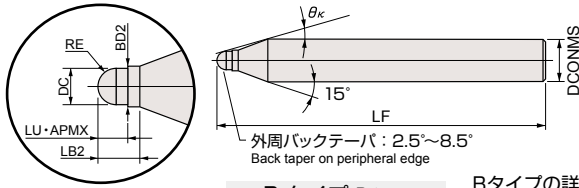

B タイプ B type

Bタイプの詳細はP.13をご確認ください
For details of B type, refer to page 13.

EPDBEH2-0.75-1.5-(S6)-TH3

商品コード Item code	在庫 Stock	寸法 Size(mm)							タイプ Type	干渉角度 Interference angle (°)	勾配角に対する実有効首下長 Effective under neck length with respect to draft angle					希望小売 価格(円) Suggested retail price (¥)						
		ボール半径 Ball radius	外径 Tool dia.	首下長 Under neck length	刃長 Flute length	首径 Neck dia.	全長 Overall length	シャンク径 Shank dia.														
		RE	DC	LU	APMX	DN	LF	DCONMS			θ_K	0.5°	1°	1.5°	2°		3°					
EPDBEH2015-6-TH3	●	0.75	1.5	6	1.35	1.45	50	4	A	7.12	6.27	6.46	6.67	6.89	7.39	5,850						
EPDBEH2015-8-TH3	●			8					A	5.95	8.34	8.60	8.88	9.19	9.88	6,140						
EPDBEH2015-10-TH3	●			10					A	5.10	10.40	10.74	11.10	11.49	12.36	6,690						
EPDBEH2015-12-TH3	●			12					A	4.47	12.47	12.88	13.32	13.79	14.85	7,250						
EPDBEH2015-14-TH3	●			14					A	3.98	14.54	15.02	15.53	16.09	17.34	7,250						
EPDBEH2015-16-TH3	●			16					A	3.58	16.60	17.16	17.75	18.39	19.82	7,250						
EPDBEH2015-18-TH3	●			18					A	3.26	18.67	19.30	19.97	20.69	22.31	7,250						
EPDBEH2015-20-TH3	●			20					A	2.99	20.74	21.44	22.18	22.99	干渉なし	7,250						
EPDBEH2015-3-S6-TH3	●			0.8					1.6	3	1.4	1.54	50	4	A	11.84	3.17	3.25	3.34	3.44	3.66	8,780
EPDBEH2015-5-S6-TH3	●									5					A	10.02	5.23	5.39	5.56	5.74	6.15	8,780
EPDBEH2015-8-S6-TH3	●	8	A		8.14	8.34	8.60	8.88		9.19					9.88	9,200						
EPDBEH2015-12-S6-TH3	●	12	A		6.51	12.47	12.88	13.32		13.79					14.85	10,830						
EPDBEH2016-4-TH3	●	0.8	1.6	4	1.4	1.54	50	4	A	8.76	4.22	4.34	4.47	4.61	4.92	8,360						
EPDBEH2016-8-TH3	●			8					A	5.82	8.35	8.62	8.90	9.20	9.89	8,360						
EPDBEH2016-12-TH3	●			12					A	4.35	12.49	12.90	13.33	13.80	14.86	8,360						
EPDBEH2016-16-TH3	●			16					A	3.47	16.62	17.17	17.77	18.40	19.84	8,360						
EPDBEH2016-20-TH3	●			20					A	2.89	20.76	21.45	22.20	23.00	干渉なし	8,360						
EPDBEH2018-4-TH3	●	0.9	1.8	4	1.6	1.73	50	4	A	8.53	4.23	4.35	4.48	4.61	4.92	7,250						
EPDBEH2018-8-TH3	●			8					A	5.55	8.37	8.63	8.91	9.21	9.89	7,250						
EPDBEH2018-12-TH3	●			12					A	4.11	12.50	12.91	13.34	13.81	14.86	7,250						
EPDBEH2018-16-TH3	●			16					A	3.26	16.64	17.19	17.78	18.41	19.83	7,250						
EPDBEH2018-20-TH3	●			20					A	2.70	20.77	21.47	22.21	23.01	干渉なし	7,250						
EPDBEH2020-2.5-TH3	●	1	2	2.5	1.7	1.94	50	4	A	10.60	2.66	2.72	2.78	2.85	3.01	5,020						
EPDBEH2020-3-TH3	●			3					A	9.72	3.18	3.25	3.34	3.43	3.63	5,020						
EPDBEH2020-4-TH3	●			4					A	8.32	4.21	4.32	4.45	4.58	4.87	5,020						
EPDBEH2020-5-TH3	●			5					A	7.27	5.25	5.39	5.55	5.73	6.11	5,720						
EPDBEH2020-6-TH3	●			6					A	6.46	6.28	6.46	6.66	6.88	7.36	5,720						
EPDBEH2020-8-TH3	●			8					A	5.27	8.35	8.60	8.88	9.18	9.84	6,140						
EPDBEH2020-10-TH3	●			10					A	4.46	10.41	10.74	11.10	11.48	12.33	6,140						
EPDBEH2020-12-TH3	●			12					A	3.86	12.48	12.88	13.31	13.77	14.82	6,140						
EPDBEH2020-13-TH3	●			13					A	3.62	13.51	13.95	14.42	14.92	16.06	6,140						
EPDBEH2020-14-TH3	●			14					A	3.40	14.55	15.02	15.53	16.07	17.30	6,140						
EPDBEH2020-16-TH3	●			16					A	3.04	16.62	17.16	17.75	18.37	19.79	6,140						
EPDBEH2020-18-TH3	●			18					A	2.75	18.68	19.30	19.96	20.67	干渉なし	6,140						
EPDBEH2020-20-TH3	●			20					A	2.51	20.75	21.44	22.18	22.97	干渉なし	6,140						
EPDBEH2020-22-TH3	●			22					A	2.31	22.82	23.58	24.40	25.27	干渉なし	8,500						
EPDBEH2020-25-TH3	●			25					A	2.06	25.92	26.79	27.72	28.72	干渉なし	8,650						
EPDBEH2020-30-TH3	●			30			A	1.75	31.09	32.14	33.26	干渉なし	干渉なし	9,900								
EPDBEH2020-35-TH3	●			35			A	1.52	36.26	37.48	38.80	干渉なし	干渉なし	13,390								
EPDBEH2020-40-TH3	●			40			A	1.34	41.42	42.83	干渉なし	干渉なし	干渉なし	13,390								
EPDBEH2020-3-S6-TH3	●			0.9			1.8	3	1.6	1.73	50	4	A	11.80	3.18	3.25	3.34	3.43	3.63	7,530		
EPDBEH2020-6-S6-TH3	●							6					A	9.04	6.28	6.46	6.66	6.88	7.36	8,570		
EPDBEH2020-8-S6-TH3	●							8					A	7.82	8.35	8.60	8.88	9.18	9.84	9,200		
EPDBEH2020-12-S6-TH3	●							12					A	6.15	12.48	12.88	13.31	13.77	14.82	9,200		
EPDBEH2020-16-S6-TH3	●							16					A	5.07	16.62	17.16	17.75	18.37	19.79	9,200		
EPDBEH2020-20-S6-TH3	●							20					A	4.31	20.75	21.44	22.18	22.97	24.76	9,200		

干渉なし : No interference.

ラインナップ

Line Up

レギュラーシャンクタイプ Regular shank type

2枚刃
2 Flutes



[注意] RE 2mm以上はバックドラフト形状ではありません。
[Note] RE 2mm or larger does not have backdraft shape.

外周バックテーパ: 2.5°~8.5°
Back taper on peripheral edge

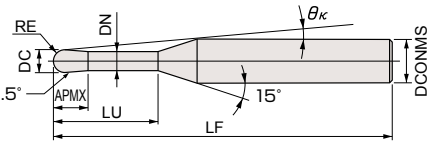

Aタイプ A type

EPDBEH2- - (S6)-TH3

超硬 TH3
Carbide

ねじり角 30° Helix angle φ4 φ6-φ12
h4 h5

ボール半径RE Ball radius	RE公差 Tolerance on RE
0.05~0.25	±0.003
0.3~6	±0.005

商品コード Item code	在庫 Stock	寸法 Size(mm)							タイプ Type	干渉角度 Interference angle (°) θ _k	勾配角に対する実有効首下長 Effective under neck length with respect to draft angle					希望小売 価格 (円) Suggested retail price (¥)
		ボール半径 RE	外径 DC	首下長 LU	刃長 APMX	首径 DN	全長 LF	シャンク径 DCONMS			0.5°	1°	1.5°	2°	3°	
											0.5°	1°	1.5°	2°	3°	
EPDBEH2025-6-TH3	●	1.25	2.5	6	2	2.4	50	4	A	5.54	6.35	6.53	6.72	6.92	7.39	7,720
EPDBEH2025-10-TH3	●			10					A	3.66	10.48	10.81	11.15	11.52	12.36	8,230
EPDBEH2025-15-TH3	●			15					A	2.57	15.65	16.15	16.69	17.27	干渉なし	8,380
EPDBEH2025-20-TH3	●			20					A	1.98	20.82	21.50	22.23	干渉なし	干渉なし	9,830
EPDBEH2025-25-TH3	●			25					A	1.61	25.99	26.85	27.78	干渉なし	干渉なし	10,460
EPDBEH2025-30-TH3	●			30					A	1.36	31.16	32.20	干渉なし	干渉なし	干渉なし	12,110
EPDBEH2030-6-TH3	●	1.5	3	6	2.5	2.88	50	6	A	8.27	6.38	6.55	6.73	6.93	7.38	6,270
EPDBEH2030-8-TH3	●			8					A	6.95	8.45	8.69	8.95	9.23	9.86	6,270
EPDBEH2030-10-TH3	●			10					A	5.98	10.51	10.83	11.17	11.53	12.35	7,250
EPDBEH2030-13-TH3	●			13					A	4.95	13.61	14.04	14.49	14.98	16.08	8,290
EPDBEH2030-16-TH3	●			16					A	4.23	16.71	17.25	17.82	18.43	19.81	8,380
EPDBEH2030-20-TH3	●			20					A	3.53	20.85	21.52	22.25	23.03	24.78	8,060
EPDBEH2030-25-TH3	●			25					A	2.93	26.02	26.87	27.79	28.78	干渉なし	8,060
EPDBEH2030-30-TH3	●			30					A	2.51	31.19	32.22	33.33	34.53	干渉なし	9,190
EPDBEH2030-35-TH3	●			35					A	2.19	36.35	37.57	38.87	40.28	干渉なし	11,580
EPDBEH2035-10-TH3	●			1.75					3.5	10	2.75	3.35	55	6	A	5.42
EPDBEH2035-15-TH3	●	15	A		3.94	15.73	16.22	16.74		17.31					18.58	10,630
EPDBEH2035-25-TH3	●	25	A		2.54	26.07	26.92	27.83		28.81					干渉なし	11,250
EPDBEH2035-35-TH3	●	35	A		1.88	36.40	37.61	38.91		干渉なし					干渉なし	14,460
EPDBEH2035-45-TH3	●	45	A		1.49	46.74	48.31	干渉なし		干渉なし					干渉なし	17,680
EPDBEH2040-8-TH3	●	2	4	8	3	3.85	55	6	A	5.71	8.49	8.71	8.96	9.22	9.81	6,450
EPDBEH2040-10-TH3	●			10					A	4.76	10.55	10.85	11.17	11.52	12.30	6,450
EPDBEH2040-12-TH3	●			12					A	4.09	12.62	12.99	13.39	13.82	14.79	8,380
EPDBEH2040-13-TH3	●			13					A	3.82	13.65	14.06	14.50	14.97	16.03	8,380
EPDBEH2040-16-TH3	●			16					A	3.18	16.76	17.27	17.82	18.42	19.76	8,380
EPDBEH2040-20-TH3	●			20					A	2.61	20.89	21.55	22.26	23.02	干渉なし	8,380
EPDBEH2040-25-TH3	●			25			A		2.13	26.06	26.90	27.80	28.77	干渉なし	8,380	
EPDBEH2040-30-TH3	●			30			A		1.79	31.23	32.25	33.34	干渉なし	干渉なし	8,380	
EPDBEH2040-35-TH3	●			35			A		1.55	36.40	37.60	38.88	干渉なし	干渉なし	9,660	
EPDBEH2040-40-TH3	●			40			A		1.37	41.56	42.94	干渉なし	干渉なし	干渉なし	10,830	
EPDBEH2040-45-TH3	●			45			A		1.22	46.73	48.29	干渉なし	干渉なし	干渉なし	14,040	
EPDBEH2040-50-TH3	●			50			A		1.11	51.90	53.64	干渉なし	干渉なし	干渉なし	15,320	
EPDBEH2050-10-TH3	●	2.5	5	10	3.5	4.85	55	6	A	2.97	10.54	10.82	11.12	11.45	干渉なし	13,250
EPDBEH2050-20-TH3	●			20					A	1.46	20.87	21.52	干渉なし	干渉なし	干渉なし	14,710
EPDBEH2050-25-TH3	●			25					A	1.17	26.04	26.86	干渉なし	干渉なし	干渉なし	14,710
EPDBEH2050-30-TH3	●			30					A	0.97	31.21	干渉なし	干渉なし	干渉なし	干渉なし	15,710
EPDBEH2050-40-TH3	●			40					A	0.73	41.55	干渉なし	干渉なし	干渉なし	干渉なし	19,530
EPDBEH2060-12-TH3	●	3	6	12	6	5.85	60	6	A	0	干渉なし	干渉なし	干渉なし	干渉なし	干渉なし	10,960
EPDBEH2060-20-TH3	●			20					A	0	干渉なし	干渉なし	干渉なし	干渉なし	干渉なし	10,960
EPDBEH2060-30-TH3	●			30					A	0	干渉なし	干渉なし	干渉なし	干渉なし	干渉なし	11,350
EPDBEH2060-50-TH3	●			50					A	0	干渉なし	干渉なし	干渉なし	干渉なし	干渉なし	13,360
EPDBEH2080-24-TH3	●	4	8	24	12	7.6	100	8	A	0	干渉なし	干渉なし	干渉なし	干渉なし	干渉なし	16,050
EPDBEH2100-30-TH3	●	5	10	30	15	9.5	100	10	A	0	干渉なし	干渉なし	干渉なし	干渉なし	干渉なし	19,980
EPDBEH2120-36-TH3	●	6	12	36	18	11.5	110	12	A	0	干渉なし	干渉なし	干渉なし	干渉なし	干渉なし	25,930

● : 標準在庫品です。 ● : Stocked items. ★ : 新商品の標準在庫品です。 ★ : Stocked items of new products. 干渉なし : No interference.

ストロングネックタイプ × ショートシャングタイプ Strong neck type × Short shank type

2枚刃
2 Flutes

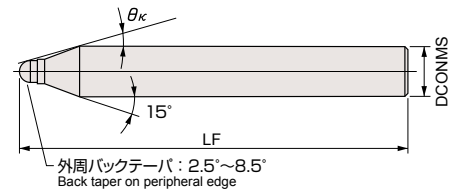
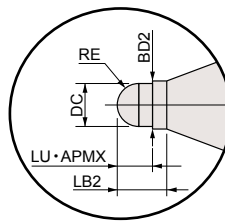

外周バックテーパ: 2.5°~8.5°
Back taper on peripheral edge

(mm)

EPDBEH2○○○F-○○○-TH3



ボール半径RE Ball radius	RE公差 Tolerance on RE
0.05~0.25	±0.003
0.3~0.5	±0.005

商品コード Item code	在庫 Stock	寸法 Size(mm)									干渉角度 Interference angle (°) θ_k	希望小売 価格(円) Suggested retail price(¥)
		ボール半径 Ball radius RE	外径 Tool dia. DC	首下長 Under neck length LU	刃長 Flute length APMX	全長 Overall length LF	シャンク径 Shank dia. DCONMS	首寸法 Neck size LB2, BD2				
EPDBEH2001F-0.08-TH3	★	0.05	0.1	0.08	0.08	35	4	0.2	0.13	20.93	16,290	
EPDBEH20015F-0.12-TH3	★	0.075	0.15	0.12	0.12	35	4	0.3	0.18	15.25	16,720	
EPDBEH2002F-0.15-TH3	★	0.1	0.2	0.15	0.15	35	4	0.3	0.25	20.23	11,680	
EPDBEH2003F-0.25-TH3	★	0.15	0.3	0.25	0.25	35	4	0.5	0.35	14.45	11,470	
EPDBEH2004F-0.3-TH3	★	0.2	0.4	0.3	0.3	35	4	0.5	0.45	14.53	7,810	
EPDBEH2005F-0.35-TH3	★	0.25	0.5	0.35	0.35	35	4	0.75	0.55	14.10	7,810	
EPDBEH2006F-0.4-TH3	★	0.3	0.6	0.4	0.4	35	4	0.75	0.65	14.16	6,740	
EPDBEH2007F-0.45-TH3	★	0.35	0.7	0.45	0.45	35	4	0.8	0.75	14.13	6,000	
EPDBEH2008F-0.5-TH3	★	0.4	0.8	0.5	0.5	35	4	0.8	0.85	14.20	6,000	
EPDBEH2009F-0.6-TH3	★	0.45	0.9	0.6	0.6	35	4	1	0.95	13.84	6,000	
EPDBEH2010F-0.8-TH3	★	0.5	1	0.8	0.8	35	4	1.2	1.05	13.47	5,020	

ストロングネックタイプ Strong neck type

2枚刃
2 Flutes



EPDBEH2○○○-○○○-TH3

商品コード Item code	在庫 Stock	寸法 Size(mm)									干渉角度 Interference angle (°) θ_k	希望小売 価格(円) Suggested retail price(¥)
		ボール半径 Ball radius RE	外径 Tool dia. DC	首下長 Under neck length LU	刃長 Flute length APMX	全長 Overall length LF	シャンク径 Shank dia. DCONMS	首寸法 Neck size LB2, BD2				
EPDBEH2001-0.08-TH3	●	0.05	0.1	0.08	0.08	45	4	0.2	0.13	20.93	16,290	
EPDBEH20015-0.12-TH3	●	0.075	0.15	0.12	0.12	45	4	0.3	0.18	15.25	16,720	
EPDBEH2002-0.15-TH3	●	0.1	0.2	0.15	0.15	50	4	0.3	0.25	20.23	11,680	
EPDBEH2003-0.25-TH3	●	0.15	0.3	0.25	0.25	50	4	0.5	0.35	14.45	11,470	
EPDBEH2004-0.3-TH3	●	0.2	0.4	0.3	0.3	50	4	0.5	0.45	14.53	7,810	
EPDBEH2005-0.35-TH3	●	0.25	0.5	0.35	0.35	50	4	0.75	0.55	14.10	7,810	
EPDBEH2006-0.4-TH3	●	0.3	0.6	0.4	0.4	50	4	0.75	0.65	14.16	6,740	
EPDBEH2007-0.45-TH3	●	0.35	0.7	0.45	0.45	50	4	0.8	0.75	14.13	6,000	
EPDBEH2008-0.5-TH3	●	0.4	0.8	0.5	0.5	50	4	0.8	0.85	14.20	6,000	
EPDBEH2009-0.6-TH3	●	0.45	0.9	0.6	0.6	50	4	1	0.95	13.84	6,000	
EPDBEH2010-0.8-TH3	●	0.5	1	0.8	0.8	50	4	1.2	1.05	13.47	5,020	

標準切削条件表

Recommended Cutting Conditions

高能率切削条件

High efficiency cutting condition

高精度切削条件

High accuracy cutting condition

高精度切削条件は18ページを参照してください。Please refer to P.18 about high accuracy cutting conditions

被削材 Work material				1		2		3		4		5	
				プリハードン鋼 Pre-hardened steels (35~45HRC)		焼入れ鋼 Hardened steels (45~55HRC)		焼入れ鋼 Hardened steels (55~65HRC)		焼入れ鋼 Hardened steels (65~68HRC)		焼入れ鋼 Hardened steels (68~72HRC)	
切り込み比率 Ratio to standard depth of cut				100%		85%		80%		65%		55%	
ボール半径RE Ball radius (mm)	外径DC Tool dia. (mm)	首下長LU Under neck length (mm)	ap (mm)	回転数 n min ⁻¹	送り速度 Vf mm/min	回転数 n min ⁻¹	送り速度 Vf mm/min	回転数 n min ⁻¹	送り速度 Vf mm/min	回転数 n min ⁻¹	送り速度 Vf mm/min	回転数 n min ⁻¹	送り速度 Vf mm/min
0.05	0.1	0.08	0.006	50,000	230	50,000	200	50,000	190	45,000	170	42,500	130
		0.2	0.006	50,000	230	50,000	200	50,000	190	45,000	170	42,500	130
		0.3	0.005	50,000	230	50,000	200	50,000	190	45,000	170	42,500	130
		0.5	0.003	50,000	230	50,000	200	50,000	190	45,000	170	42,500	130
0.075	0.15	0.12	0.009	50,000	280	46,000	230	42,000	180	37,500	160	35,500	120
		0.3	0.009	50,000	280	46,000	230	42,000	180	37,500	160	35,500	120
		0.5	0.008	50,000	280	46,000	230	42,000	180	37,500	160	35,500	120
		0.75	0.007	50,000	280	46,000	230	42,000	180	37,500	160	35,500	120
0.1	0.2	1	0.005	46,000	230	41,400	190	37,800	150	33,750	130	31,950	100
		0.15	0.016	50,000	330	45,500	270	42,000	210	37,800	190	35,700	150
		0.3	0.016	50,000	330	45,500	270	42,000	210	37,800	190	35,700	150
		0.5	0.016	50,000	330	45,500	270	42,000	210	37,800	190	35,700	150
		0.75	0.014	50,000	330	45,500	270	42,000	210	37,800	190	35,700	150
		1	0.011	50,000	330	45,500	270	42,000	210	37,800	190	35,700	150
		1.25	0.009	45,900	270	40,500	220	37,800	170	34,020	150	32,130	120
		1.5	0.006	45,900	270	40,500	220	37,800	170	34,020	150	32,130	120
0.15	0.3	2	0.006	45,900	270	40,500	220	37,800	170	34,020	150	32,130	120
		2.5	0.005	40,800	210	36,000	170	33,600	130	30,240	120	28,560	90
		3	0.003	40,800	210	36,000	170	33,600	130	30,240	120	28,560	90
		0.25	0.022	50,000	450	45,000	380	42,000	340	37,800	300	35,700	240
		0.5	0.022	50,000	450	45,000	380	42,000	340	37,800	300	35,700	240
		0.75	0.019	50,000	450	45,000	380	42,000	340	37,800	300	35,700	240
		1	0.017	50,000	450	45,000	380	42,000	340	37,800	300	35,700	240
		1.25	0.015	50,000	450	45,000	380	42,000	340	37,800	300	35,700	240
		1.5	0.013	50,000	450	45,000	380	42,000	340	37,800	300	35,700	240
0.2	0.4	2	0.01	45,900	370	40,500	310	37,800	270	34,020	250	32,130	190
		2.5	0.008	45,900	370	40,500	310	37,800	270	34,020	250	32,130	190
		3	0.006	45,900	370	40,500	310	37,800	270	34,020	250	32,130	190
		3.5	0.004	36,720	260	29,400	210	26,400	180	23,760	160	22,440	130
		4	0.003	36,720	260	29,400	210	26,400	180	23,760	160	22,440	130
		0.3	0.034	50,000	770	46,800	660	43,680	610	39,310	550	37,130	430
		0.5	0.034	50,000	770	46,800	660	43,680	610	39,310	550	37,130	430
		0.75	0.034	50,000	770	46,800	660	43,680	610	39,310	550	37,130	430
		1	0.032	50,000	770	46,800	660	43,680	610	39,310	550	37,130	430
		1.5	0.027	50,000	660	46,800	470	43,680	440	39,310	390	37,130	310
		2	0.022	50,000	550	46,800	470	43,680	440	39,310	390	37,130	310
0.25	0.5	2.5	0.018	36,720	360	32,400	290	36,290	270	32,660	250	30,850	190
		3	0.013	36,720	360	32,400	290	36,290	270	32,660	250	30,850	190
		3.5	0.01	36,720	360	32,400	290	36,290	270	32,660	250	30,850	190
		4	0.008	36,720	360	32,400	290	36,290	270	32,660	250	30,850	190
		4.5	0.006	32,640	310	28,800	250	26,880	230	24,190	210	22,850	160
		5	0.004	32,640	310	28,800	250	26,880	230	24,190	210	22,850	160
		0.35	0.036	50,000	1,190	47,130	1,050	43,930	740	39,820	670	37,560	520
		0.75	0.036	50,000	1,190	47,130	1,050	43,930	740	39,820	670	37,560	520
		1	0.036	50,000	1,190	47,130	1,050	43,930	740	39,820	670	37,560	520
		1.5	0.032	50,000	1,190	47,130	1,050	43,930	680	39,820	610	37,560	480
		2	0.028	50,000	960	47,130	840	43,930	680	39,820	610	37,560	480
		2.5	0.026	45,450	650	42,840	570	39,940	500	36,220	450	34,180	350
		3	0.024	45,450	650	42,840	570	39,940	390	36,220	350	34,180	270
4	0.016	34,970	500	32,950	520	30,730	390	28,540	350	26,290	270		
5	0.014	34,970	500	32,950	520	30,730	390	28,540	350	26,290	270		
5.5	0.012	31,080	420	29,300	370	27,310	320	24,770	290	23,370	230		
6	0.01	31,080	420	29,300	370	27,310	320	24,770	290	23,370	230		
7	0.008	31,080	420	29,300	370	27,310	320	24,770	290	23,370	230		
8	0.006	31,080	420	29,300	370	27,310	320	24,770	290	23,370	230		
0.3	0.6	0.4	0.06	50,000	1,950	48,000	1,730	44,800	1,340	40,320	1,210	38,080	940
		0.75	0.06	50,000	1,950	48,000	1,730	44,800	1,340	40,320	1,210	38,080	940

高能率切削条件

High efficiency cutting condition

高精度切削条件

High accuracy cutting condition

高精度切削条件は18ページを参照してください。Please refer to P.18 about high accuracy cutting conditions

被削材 Work material				1		2		3		4		5	
				プリハードン鋼 Pre-hardened steels (35~45HRC)		焼入れ鋼 Hardened steels (45~55HRC)		焼入れ鋼 Hardened steels (55~65HRC)		焼入れ鋼 Hardened steels (65~68HRC)		焼入れ鋼 Hardened steels (68~72HRC)	
切り込み比率 Ratio to standard depth of cut				100%		85%		80%		65%		55%	
ボール半径RE Ball radius (mm)	外径DC Tool dia. (mm)	首下長LU Under neck length (mm)	ap (mm)	回転数 n min ⁻¹	送り速度 Vf mm/min	回転数 n min ⁻¹	送り速度 Vf mm/min	回転数 n min ⁻¹	送り速度 Vf mm/min	回転数 n min ⁻¹	送り速度 Vf mm/min	回転数 n min ⁻¹	送り速度 Vf mm/min
0.3	0.6	1	0.06	50,000	1,950	48,000	1,730	44,800	1,340	40,320	1,210	38,080	940
		1.5	0.055	50,000	1,950	48,000	1,730	44,800	1,340	40,320	1,210	38,080	940
		2	0.05	50,000	1,950	48,000	1,730	44,800	1,340	40,320	1,210	38,080	940
		2.5	0.036	50,000	1,560	48,000	1,380	44,800	990	40,320	890	38,080	690
		3	0.033	50,000	1,560	48,000	1,380	44,800	990	40,320	890	38,080	690
		3.5	0.028	48,960	1,450	43,200	1,180	40,320	840	36,290	760	34,270	590
		4	0.021	48,960	1,450	43,200	1,180	40,320	770	36,290	690	34,270	540
		4.5	0.018	45,900	1,070	40,500	880	37,800	680	34,020	610	32,130	480
		5	0.016	39,780	930	35,100	760	32,760	590	29,480	530	27,850	410
		5.5	0.014	39,780	930	35,100	760	32,760	590	29,480	530	27,850	410
		6	0.012	39,780	930	35,100	760	32,760	590	29,480	530	27,850	410
		7	0.012	27,200	600	24,000	490	22,400	420	20,160	370	19,040	290
8	0.012	27,200	600	24,000	490	22,400	380	20,160	340	19,040	270		
9	0.01	27,200	600	24,000	490	22,400	380	20,160	340	19,040	270		
10	0.007	23,800	530	21,000	430	19,600	330	17,640	300	16,660	230		
12	0.006	20,400	420	18,000	350	16,800	270	15,120	240	14,280	190		
0.35	0.7	0.45	0.073	50,000	2,160	48,000	1,930	44,800	1,190	40,320	1,070	38,080	830
		2	0.073	50,000	2,160	48,000	1,930	44,800	1,190	40,320	1,070	38,080	830
		4	0.033	48,960	1,600	43,200	1,320	43,870	850	39,480	760	37,370	590
		6	0.022	39,780	1,030	35,100	850	35,650	640	32,080	580	30,370	450
		8	0.016	27,200	630	24,000	520	24,370	420	21,940	380	20,760	300
0.4	0.8	0.5	0.12	50,000	2,400	48,000	2,590	44,800	1,880	40,320	1,690	38,080	1,320
		1	0.12	50,000	2,400	48,000	2,590	44,800	1,880	40,320	1,690	38,080	1,320
		1.5	0.12	50,000	2,400	48,000	2,590	44,800	1,880	40,320	1,690	38,080	1,320
		2	0.096	50,000	2,400	48,000	2,590	44,800	1,880	40,320	1,690	38,080	1,320
		2.5	0.088	50,000	2,400	48,000	2,590	44,800	1,880	40,320	1,690	38,080	1,320
		3	0.08	50,000	2,400	48,000	2,590	44,800	1,880	40,320	1,690	38,080	1,320
		4	0.063	50,000	2,400	48,000	2,590	44,800	1,880	40,320	1,690	38,080	1,320
		5	0.047	48,960	2,110	43,200	2,120	40,320	1,520	36,290	1,370	34,270	1,070
		6	0.033	42,840	1,730	37,800	1,430	35,280	1,250	31,750	1,120	29,990	870
		8	0.016	35,360	1,020	31,200	840	29,120	730	26,210	660	24,750	510
10	0.016	27,200	740	24,000	610	22,400	530	20,160	480	19,040	370		
12	0.01	27,200	740	24,000	610	22,400	530	20,160	480	19,040	370		
0.45	0.9	0.6	0.108	50,000	2,820	45,600	2,410	42,560	2,140	38,300	1,930	36,180	1,500
		2	0.108	50,000	2,820	45,600	2,410	42,560	2,140	38,300	1,930	36,180	1,500
		4	0.065	48,450	2,370	42,750	1,960	39,900	1,740	35,910	1,560	33,920	1,220
		6	0.044	40,700	1,520	35,910	1,250	33,520	1,110	30,160	1,000	28,490	780
		8	0.029	31,010	1,050	27,360	870	25,540	770	22,980	690	21,710	540
0.5	1	0.8	0.18	45,900	3,100	43,200	2,720	37,800	2,270	34,020	2,040	32,130	1,590
		1.5	0.18	45,900	3,100	43,200	2,720	37,800	2,270	34,020	2,040	32,130	1,590
		2	0.16	45,900	3,100	43,200	2,720	37,800	2,270	34,020	2,040	32,130	1,590
		2.5	0.16	45,900	3,100	43,200	2,720	37,800	2,270	34,020	2,040	32,130	1,590
		3	0.16	45,900	3,100	43,200	2,720	37,800	2,270	34,020	2,040	32,130	1,590
		4	0.112	45,900	3,100	43,200	2,720	37,800	2,270	34,020	2,040	32,130	1,590
		5	0.072	39,780	2,600	43,200	2,540	32,760	1,840	29,480	1,650	27,850	1,280
		6	0.048	38,560	2,320	38,880	2,350	29,480	1,380	26,540	1,240	25,060	970
		7	0.048	33,050	1,340	31,590	1,320	27,220	1,060	24,490	960	23,130	740
		8	0.048	33,050	1,340	31,590	1,320	27,220	980	24,490	880	23,130	690
		9	0.036	33,050	1,340	31,590	1,320	27,220	980	24,490	880	23,130	690
		10	0.03	33,050	1,340	31,590	1,320	27,220	980	24,490	880	23,130	690
		12	0.02	24,480	940	21,600	770	20,160	690	18,140	620	17,140	480
		13	0.018	24,480	940	21,600	770	20,160	690	18,140	620	17,140	480
		14	0.016	24,480	940	21,600	770	20,160	690	18,140	620	17,140	480
16	0.012	24,480	940	21,600	770	20,160	690	18,140	620	17,140	480		
18	0.01	21,420	770	18,900	640	17,640	560	15,880	510	14,990	400		
20	0.008	18,360	660	16,200	540	15,120	480	13,610	440	12,850	340		

【注意】ご使用にあたっては、17ページの表下の項目と注意を参照してください。【Note】Upon usage, please refer to comments and notes below table on page 17.

標準切削条件表

Recommended Cutting Conditions

高能率切削条件

High efficiency cutting condition

高精度切削条件

High accuracy cutting condition

高精度切削条件は18ページを参照してください。Please refer to P.18 about high accuracy cutting conditions

被削材 Work material				1		2		3		4		5	
				プリハードン鋼 Pre-hardened steels (35~45HRC)		焼入れ鋼 Hardened steels (45~55HRC)		焼入れ鋼 Hardened steels (55~65HRC)		焼入れ鋼 Hardened steels (65~68HRC)		焼入れ鋼 Hardened steels (68~72HRC)	
切り込み比率 Ratio to standard depth of cut				100%		85%		80%		65%		55%	
ボール半径RE Ball radius (mm)	外径DC Tool dia. (mm)	首下長LU Under neck length (mm)	ap (mm)	回転数 n min ⁻¹	送り速度 Vf mm/min	回転数 n min ⁻¹	送り速度 Vf mm/min	回転数 n min ⁻¹	送り速度 Vf mm/min	回転数 n min ⁻¹	送り速度 Vf mm/min	回転数 n min ⁻¹	送り速度 Vf mm/min
0.55	1.1	2	0.16	42,840	2,930	37,800	2,450	35,280	2,180	31,750	1,960	29,990	1,520
		4	0.112	42,840	2,930	37,800	2,450	35,280	2,180	31,750	1,960	29,990	1,520
		6	0.048	33,810	1,710	29,840	1,430	27,850	1,270	25,060	1,140	23,670	890
		8	0.048	31,210	1,310	27,540	1,100	25,700	980	23,130	880	21,850	680
		10	0.03	31,210	1,310	27,540	1,100	25,700	980	23,130	880	21,850	680
0.6	1.2	2	0.154	39,230	2,720	36,920	2,560	32,310	1,860	29,080	1,670	27,460	1,300
		3	0.154	39,230	2,720	36,920	2,560	32,310	1,860	29,080	1,670	27,460	1,300
		4	0.128	39,230	2,720	36,920	2,560	32,310	1,860	29,080	1,670	27,460	1,300
		6	0.088	39,230	2,720	36,920	2,560	32,310	1,860	29,080	1,670	27,460	1,300
		8	0.048	31,820	2,070	30,240	2,060	26,210	1,050	23,590	940	22,280	730
		10	0.042	29,380	1,320	27,000	1,070	24,190	870	21,770	780	20,560	610
		12	0.036	29,380	1,320	25,920	1,030	24,190	870	21,770	780	20,560	610
0.7	1.4	3	0.158	33,420	2,350	29,480	1,990	27,520	1,790	24,770	1,610	23,390	1,250
		8	0.088	27,850	1,810	24,570	1,530	22,930	1,380	20,640	1,240	19,490	960
		12	0.042	25,700	1,250	22,680	1,060	21,170	950	19,050	860	17,990	670
		16	0.028	19,040	870	16,800	740	15,680	670	14,110	600	13,330	470
0.75	1.5	2	0.192	35,700	3,210	31,500	2,550	29,400	2,210	26,460	1,990	24,990	1,540
		2.5	0.192	35,700	3,210	31,500	2,550	29,400	2,210	26,460	1,990	24,990	1,540
		3	0.192	35,700	3,210	31,500	2,550	29,400	2,210	26,460	1,990	24,990	1,540
		4	0.16	35,700	3,210	31,500	2,550	29,400	2,210	26,460	1,990	24,990	1,540
		5	0.16	35,700	3,210	31,500	2,550	29,400	2,210	26,460	1,990	24,990	1,540
		6	0.16	35,700	3,210	31,500	2,550	29,400	2,210	26,460	1,990	24,990	1,540
		8	0.072	27,850	1,810	24,570	1,430	22,930	1,240	20,640	1,120	19,490	870
		10	0.072	25,700	1,670	22,680	1,320	21,170	1,140	19,050	1,030	17,990	800
		12	0.072	25,700	1,390	22,680	1,100	21,170	950	19,050	860	17,990	670
		14	0.06	22,850	1,170	20,160	930	18,820	800	16,930	720	15,990	560
		16	0.03	19,040	970	16,800	770	15,680	670	14,110	600	13,330	470
0.8	1.6	4	0.23	33,110	3,340	29,210	2,850	25,320	2,130	22,780	1,920	21,520	1,490
		8	0.176	30,940	2,490	27,300	2,130	23,660	1,590	21,290	1,430	20,110	1,110
		12	0.078	27,850	2,180	24,570	1,860	21,290	1,290	19,170	1,160	18,100	900
		16	0.048	23,870	1,330	21,060	1,140	19,660	990	17,690	890	16,710	690
		20	0.032	17,680	930	15,600	800	14,560	690	13,100	620	12,380	490
0.9	1.8	4	0.29	28,730	2,410	25,350	2,010	23,660	1,700	21,290	1,530	20,110	1,190
		8	0.208	28,730	2,410	25,350	2,010	23,660	1,700	21,290	1,530	20,110	1,190
		12	0.084	23,870	1,500	21,060	1,250	19,660	1,060	17,690	960	16,710	740
		16	0.054	23,870	1,500	21,060	1,250	19,660	1,060	17,690	960	16,710	740
		20	0.036	17,680	1,050	15,600	880	14,560	740	13,100	670	12,380	520
1	2	2.5	0.32	26,780	3,620	23,630	3,050	22,050	2,650	19,850	2,380	18,740	1,850
		3	0.32	26,780	3,620	23,630	3,050	22,050	2,650	19,850	2,380	18,740	1,850
		4	0.32	26,780	3,620	23,630	3,050	22,050	2,650	19,850	2,380	18,740	1,850
		5	0.32	26,780	3,620	23,630	3,050	22,050	2,650	19,850	2,380	18,740	1,850
		6	0.32	26,780	3,210	23,630	2,690	22,050	2,380	19,850	2,140	18,740	1,670
		8	0.224	26,780	3,210	23,630	2,690	22,050	2,380	19,850	2,140	18,740	1,670
		10	0.168	24,990	2,700	22,050	2,250	19,110	1,470	17,200	1,320	16,240	1,030
		12	0.096	22,490	2,430	19,850	2,050	17,200	1,320	15,480	1,190	14,620	930
		13	0.096	22,490	2,430	19,850	2,020	15,880	1,020	14,290	920	13,500	710
		14	0.096	22,490	2,110	18,430	1,630	15,880	1,020	14,290	920	13,500	710
		16	0.096	20,890	1,350	18,430	1,470	15,880	910	14,290	820	13,500	640
		18	0.072	19,280	1,250	18,430	1,350	15,880	910	14,290	820	13,500	640
		20	0.06	19,280	1,250	18,430	1,130	15,880	910	14,290	820	13,500	640
		22	0.04	15,170	930	13,390	770	14,990	820	13,500	730	12,750	570
		25	0.04	14,280	870	12,600	730	14,110	770	12,700	690	12,000	540
		30	0.024	14,280	870	12,600	730	14,110	770	12,700	690	12,000	540
35	0.02	12,500	720	11,030	600	10,290	530	9,260	470	8,750	370		
40	0.018	10,710	620	9,450	510	8,820	450	7,940	410	7,500	320		

高能率切削条件

High efficiency cutting condition

高精度切削条件

High accuracy cutting condition

高精度切削条件は18ページを参照してください。Please refer to P.18 about high accuracy cutting conditions

被削材 Work material				1 プリハードン鋼 Pre-hardened steels (35~45HRC)		2 焼入れ鋼 Hardened steels (45~55HRC)		3 焼入れ鋼 Hardened steels (55~68HRC)		4 焼入れ鋼 Hardened steels (65~68HRC)		5 焼入れ鋼 Hardened steels (68~72HRC)	
切り込み比率 Ratio to standard depth of cut				100%		85%		80%		65%		55%	
ボール半径RE Ball radius (mm)	外径DC Tool dia. (mm)	首下長LU Under neck length (mm)	ap (mm)	回転数 n min ⁻¹	送り速度 Vf mm/min	回転数 n min ⁻¹	送り速度 Vf mm/min	回転数 n min ⁻¹	送り速度 Vf mm/min	回転数 n min ⁻¹	送り速度 Vf mm/min	回転数 n min ⁻¹	送り速度 Vf mm/min
1.25	2.5	6	0.4	23,590	3,800	20,810	3,090	19,430	2,530	17,480	2,280	16,610	1,820
		10	0.272	23,590	3,800	20,810	3,090	19,430	2,530	17,480	2,280	16,610	1,820
		15	0.12	18,400	2,130	16,230	2,020	15,150	1,420	13,640	1,280	12,950	1,020
		20	0.096	16,980	1,640	16,230	1,450	13,990	1,090	12,590	980	11,960	790
		25	0.078	16,980	1,480	14,990	1,200	13,990	980	12,590	880	11,960	710
		30	0.044	12,580	1,150	11,100	930	10,360	770	9,320	690	8,860	550
1.5	3	6	0.48	20,400	4,100	18,000	3,400	16,800	3,020	15,120	2,720	14,360	2,180
		8	0.48	20,400	4,100	18,000	3,400	16,800	3,020	15,120	2,720	14,360	2,180
		10	0.336	20,400	4,100	18,000	3,400	16,800	3,020	15,120	2,720	14,360	2,180
		13	0.252	19,040	3,060	16,800	2,540	15,680	2,260	14,110	2,030	13,410	1,630
		16	0.252	19,040	2,760	16,800	2,290	14,560	1,890	13,100	1,700	12,450	1,360
		20	0.144	15,910	1,920	14,040	1,590	12,100	1,310	10,890	1,180	10,340	940
		25	0.096	15,910	1,920	14,040	1,590	12,100	1,310	10,890	1,180	10,340	940
		30	0.096	14,690	1,770	12,960	1,470	12,100	1,310	10,890	1,180	10,340	940
1.75	3.5	10	0.328	15,190	2,750	13,410	2,240	12,510	1,830	11,260	1,650	10,700	1,320
		15	0.288	15,190	2,750	13,410	2,240	12,510	1,830	11,260	1,650	10,700	1,320
		25	0.168	12,620	1,710	11,140	1,390	10,400	1,140	9,360	1,030	8,890	820
		35	0.072	12,620	1,710	11,140	1,390	10,400	1,140	9,360	1,030	8,890	820
		45	0.072	9,350	1,200	8,250	980	7,700	800	6,930	720	6,580	580
2	4	8	0.48	14,660	3,960	12,940	3,300	12,080	2,900	10,870	2,610	10,320	2,090
		10	0.48	14,660	3,960	12,940	3,300	12,080	2,900	10,870	2,610	10,320	2,090
		12	0.384	14,660	3,960	12,940	3,300	12,080	2,900	10,870	2,610	10,320	2,090
		13	0.384	14,660	3,960	12,940	3,300	12,080	2,900	10,870	2,610	10,320	2,090
		16	0.336	14,660	3,960	12,940	3,300	12,080	2,900	10,870	2,610	10,320	2,090
		20	0.336	12,710	2,750	11,210	2,290	10,470	2,010	9,420	1,810	8,950	1,450
		25	0.192	11,440	2,220	10,090	2,160	9,420	1,630	8,480	1,460	8,050	1,170
		30	0.128	10,560	1,710	9,320	1,430	8,690	1,250	7,820	1,130	7,430	900
		35	0.08	10,560	1,710	9,320	1,430	8,690	1,250	7,820	1,130	7,430	900
		40	0.08	10,560	1,710	9,320	1,430	8,690	1,250	7,820	1,130	7,430	900
2.5	5	10	0.584	10,710	3,210	9,450	2,840	8,820	2,380	7,940	2,140	7,540	1,710
		20	0.42	10,710	3,210	9,450	2,840	8,820	2,380	7,940	2,140	7,540	1,710
		25	0.42	9,950	2,980	8,780	2,630	8,190	2,210	7,370	1,990	7,000	1,590
		30	0.24	8,950	2,690	7,900	2,370	7,370	1,990	6,630	1,790	6,300	1,430
		40	0.16	8,260	1,490	7,290	1,310	6,800	1,100	6,120	990	5,820	790
3	6	12	0.48	11,480	4,250	10,130	3,460	9,450	2,840	8,510	2,550	8,080	2,040
		20	0.4	10,840	3,730	9,560	3,030	8,930	2,490	8,030	2,240	7,630	1,790
		30	0.336	8,840	2,120	7,800	2,030	7,280	1,570	6,550	1,410	6,220	1,130
		50	0.12	7,340	1,590	6,480	1,400	6,050	1,180	5,440	1,060	5,170	850
4	8	24	0.5	8,750	3,420	7,550	2,600	7,100	2,450	6,390	1,850	5,750	1,270
5	10	30	0.6	7,000	3,000	6,050	2,250	5,680	2,130	5,110	1,610	4,600	1,030
6	12	36	0.8	5,850	2,600	5,050	1,980	4,720	1,840	4,250	1,440	3,820	880

※(1) apは被削材グループ1での目安を示しています。その他のグループの場合は、上表の切り込み比率を目安に調整してください。

※(2) リブ加工や止まり溝など、切りくすがつまりやすい切削の場合、切り込み設定は基本切り込み値に切り込み比率をかけて算出した切り込み量を、さらにその80%まで小さくして使用してください。

※(3) aeの設定はap×切り込み比率×3~5倍を目安に調整してください。仕上げ加工を行う場合、理論カスプハイトを計算し設定してください。

※(1) ap is shown as the criteria for Group 1 workpieces. For other groups, adjust the cutting depth according to the cutting depth factors in the above table.

※(2) When performing cutting where cutting chips may cause clogging, such as for rib cutting, blind grooves, etc., cutting depth setting should be set by multiplying a cutting depth factor to calculate the cutting depth amount, and this amount should then be reduced to 80% of the calculated value.

※(3) Adjust by setting ae to (3 to 5) × (ap) × (cutting depth ratio). When performing finishing processing, calculate the theoretical cusp height and set accordingly.

【切り込み設定例】 EPDBEH2020-10-TH3の工具で焼入れ鋼(50HRC)をリブ溝等高線切削する場合、
切り込み=0.168(ap)×0.85(焼入れ鋼グループ2の切り込み比率)×0.8(閉鎖域の切削)=0.11mm

Cutting depth setting example: When cutting rib groove contours in hardened steel (50HRC) using an EPDBEH2020-10-TH3 tool:
Cutting depth = 0.168 (ap) × 0.85 (cutting depth factor for Group 2 hardened steel) × 0.8 (for closed-area cutting) = 0.11mm

- 【注意】**
- ① 基本的にはDry(エアブロー)切削を推奨しますが、被削材、加工形状に合わせて、適切なクーラントを使用してください。
 - ② この標準切削条件表は切削条件の目安を示すものです。実際の加工では加工形状、目的、使用機械等により条件を調整してください。
 - ③ 機械の回転数が足りない場合は、回転数と送り速度を同じ比率で下げてください。

- 【Note】**
- ① Although basically dry (air blow) cutting is recommended, please use appropriate coolant according to the work material and machining shape.
 - ② These Recommended Cutting Conditions indicate only the rule of a thumb for the cutting conditions. In actual machining, the condition should be adjusted according to the machining shape, purpose and the machine type.
 - ③ If the rpm of the machine is low, lower the feed rate also to put the rpm and feed rate in the same ratio.

標準切削条件表

Recommended Cutting Conditions

高能率切削条件
High efficiency cutting condition

高精度切削条件
High accuracy cutting condition

高能率切削条件は14ページを参照してください。Please refer to P.14 about high efficiency cutting conditions

被削材 Work material				1		2		3		4		5	
				プリハードン鋼 Pre-hardened steels (35~45HRC)		焼入れ鋼 Hardened steels (45~55HRC)		焼入れ鋼 Hardened steels (55~65HRC)		焼入れ鋼 Hardened steels (65~68HRC)		焼入れ鋼 Hardened steels (68~72HRC)	
切り込み比率 Ratio to standard depth of cut				100%		85%		80%		65%		55%	
ボール半径RE Ball radius (mm)	外径DC Tool dia. (mm)	首下長LU Under neck length (mm)	ap (mm)	回転数 n min ⁻¹	送り速度 Vf mm/min	回転数 n min ⁻¹	送り速度 Vf mm/min	回転数 n min ⁻¹	送り速度 Vf mm/min	回転数 n min ⁻¹	送り速度 Vf mm/min	回転数 n min ⁻¹	送り速度 Vf mm/min
0.05	0.1	0.08	0.003	50,000	230	50,000	200	50,000	190	45,000	170	42,500	130
		0.2	0.003	50,000	230	50,000	200	50,000	190	45,000	170	42,500	130
		0.3	0.002	50,000	230	50,000	200	50,000	190	45,000	170	42,500	130
		0.5	0.002	50,000	230	50,000	200	50,000	190	45,000	170	42,500	130
0.075	0.15	0.12	0.007	50,000	280	46,000	230	42,000	180	37,500	160	35,500	120
		0.3	0.007	50,000	280	46,000	230	42,000	180	37,500	160	35,500	120
		0.5	0.006	50,000	280	46,000	230	42,000	180	37,500	160	35,500	120
		0.75	0.005	50,000	280	46,000	230	42,000	180	37,500	160	35,500	120
0.1	0.2	1	0.003	46,000	230	41,400	190	37,800	150	33,750	130	31,950	100
		0.15	0.012	50,000	330	45,500	270	42,000	210	37,800	190	35,700	150
		0.3	0.012	50,000	330	45,500	270	42,000	210	37,800	190	35,700	150
		0.5	0.012	50,000	330	45,500	270	42,000	210	37,800	190	35,700	150
		0.75	0.01	50,000	330	45,500	270	42,000	210	37,800	190	35,700	150
		1	0.009	50,000	330	45,500	270	42,000	210	37,800	190	35,700	150
		1.25	0.006	45,900	270	40,500	220	37,800	170	34,020	150	32,130	120
		1.5	0.006	45,900	270	40,500	220	37,800	170	34,020	150	32,130	120
0.15	0.3	2	0.005	45,900	270	40,500	220	37,800	170	34,020	150	32,130	120
		2.5	0.004	40,800	210	36,000	170	33,600	130	30,240	120	28,560	90
		3	0.002	40,800	210	36,000	170	33,600	130	30,240	120	28,560	90
		0.25	0.016	50,000	450	45,000	380	42,000	340	37,800	300	35,700	240
		0.5	0.016	50,000	450	45,000	380	42,000	340	37,800	300	35,700	240
		0.75	0.014	50,000	450	45,000	380	42,000	340	37,800	300	35,700	240
		1	0.013	50,000	450	45,000	380	42,000	340	37,800	300	35,700	240
		1.25	0.011	50,000	450	45,000	380	42,000	340	37,800	300	35,700	240
		1.5	0.01	50,000	450	45,000	380	42,000	340	37,800	300	35,700	240
		2	0.007	45,900	370	40,500	310	37,800	270	34,020	250	32,130	190
0.2	0.4	2.5	0.006	45,900	370	40,500	310	37,800	270	34,020	250	32,130	190
		3	0.005	45,900	370	40,500	310	37,800	270	34,020	250	32,130	190
		3.5	0.003	36,720	260	29,400	210	26,400	180	23,760	160	22,440	130
		4	0.002	36,720	260	29,400	210	26,400	180	23,760	160	22,440	130
		0.3	0.034	40,800	450	36,000	360	33,600	340	30,240	300	28,560	240
		0.5	0.034	40,800	450	36,000	360	33,600	340	30,240	300	28,560	240
		0.75	0.034	40,800	450	36,000	360	33,600	340	30,240	300	28,560	240
		1	0.032	40,800	450	36,000	360	33,600	340	30,240	300	28,560	240
		1.5	0.027	40,800	450	36,000	360	33,600	340	30,240	300	28,560	240
		2	0.022	40,800	450	36,000	360	33,600	340	30,240	300	28,560	240
		2.5	0.013	36,720	360	32,400	290	30,240	270	27,220	250	25,700	190
		0.25	0.5	3	0.009	36,720	360	32,400	290	30,240	270	27,220	250
3.5	0.006			36,720	360	32,400	290	30,240	270	27,220	250	25,700	190
4	0.004			36,720	360	32,400	290	30,240	270	27,220	250	25,700	190
4.5	0.003			32,640	310	28,800	250	26,880	230	24,190	210	22,850	160
5	0.002			32,640	310	28,800	250	26,880	230	24,190	210	22,850	160
0.35	0.036			34,000	610	30,000	540	28,000	480	25,200	430	23,800	330
0.75	0.036			34,000	610	30,000	540	28,000	480	25,200	430	23,800	330
1	0.036			34,000	610	30,000	540	28,000	480	25,200	430	23,800	330
1.5	0.032			34,000	610	30,000	540	28,000	480	25,200	430	23,800	330
2	0.028			34,000	610	30,000	540	28,000	480	25,200	430	23,800	330
2.5	0.026			30,600	500	27,000	440	25,200	390	22,680	350	21,420	270
3	0.024			30,600	500	27,000	440	25,200	390	22,680	350	21,420	270
4	0.016	30,600	500	27,000	440	25,200	390	22,680	350	21,420	270		
5	0.014	30,600	500	27,000	440	25,200	390	22,680	350	21,420	270		
0.3	0.6	5.5	0.006	27,200	420	24,000	370	22,400	320	20,160	290	19,040	230
		6	0.005	27,200	420	24,000	370	22,400	320	20,160	290	19,040	230
		7	0.004	27,200	420	24,000	370	22,400	320	20,160	290	19,040	230
		8	0.003	27,200	420	24,000	370	22,400	320	20,160	290	19,040	230
		0.4	0.04	34,000	880	30,000	720	28,000	560	25,200	500	23,800	390
		0.75	0.04	34,000	880	30,000	720	28,000	560	25,200	500	23,800	390

高効率切削条件
High efficiency cutting condition

高精度切削条件
High accuracy cutting condition

高効率切削条件は14ページを参照してください。 Please refer to P.14 about high efficiency cutting conditions

被削材 Work material				1		2		3		4		5	
				プリハードン鋼 Pre-hardened steels (35~45HRC)		焼入れ鋼 Hardened steels (45~55HRC)		焼入れ鋼 Hardened steels (55~65HRC)		焼入れ鋼 Hardened steels (65~68HRC)		焼入れ鋼 Hardened steels (68~72HRC)	
切り込み比率 Ratio to standard depth of cut				100%		85%		80%		65%		55%	
ボール半径RE Ball radius (mm)	外径DC Tool dia. (mm)	首下長LU Under neck length (mm)	ap (mm)	回転数 n min ⁻¹	送り速度 Vf mm/min	回転数 n min ⁻¹	送り速度 Vf mm/min	回転数 n min ⁻¹	送り速度 Vf mm/min	回転数 n min ⁻¹	送り速度 Vf mm/min	回転数 n min ⁻¹	送り速度 Vf mm/min
0.3	0.6	1	0.04	34,000	880	30,000	720	28,000	560	25,200	500	23,800	390
		1.5	0.038	34,000	880	30,000	720	28,000	560	25,200	500	23,800	390
		2	0.034	34,000	880	30,000	720	28,000	560	25,200	500	23,800	390
		2.5	0.03	34,000	880	30,000	720	28,000	560	25,200	500	23,800	390
		3	0.027	34,000	880	30,000	720	28,000	560	25,200	500	23,800	390
		3.5	0.023	30,600	760	27,000	620	25,200	480	22,680	430	21,420	340
		4	0.019	30,600	760	27,000	620	25,200	480	22,680	430	21,420	340
		4.5	0.018	30,600	720	27,000	580	25,200	450	22,680	410	21,420	320
		5	0.016	30,600	720	27,000	580	25,200	450	22,680	410	21,420	320
		5.5	0.014	30,600	720	27,000	580	25,200	450	22,680	410	21,420	320
		6	0.012	30,600	720	27,000	580	25,200	450	22,680	410	21,420	320
		7	0.006	27,200	600	24,000	490	22,400	380	20,160	340	19,040	270
8	0.006	27,200	600	24,000	490	22,400	380	20,160	340	19,040	270		
9	0.005	27,200	600	24,000	490	22,400	380	20,160	340	19,040	270		
10	0.004	23,800	530	21,000	430	19,600	330	17,640	300	16,660	230		
12	0.003	20,400	420	18,000	350	16,800	270	15,120	240	14,280	190		
0.35	0.7	0.45	0.049	34,000	980	30,000	810	28,000	660	25,200	590	23,800	460
		2	0.049	34,000	980	30,000	810	28,000	660	25,200	590	23,800	460
		4	0.027	30,600	840	27,000	690	25,200	560	22,680	510	21,420	400
		6	0.022	30,600	790	27,000	650	25,200	540	22,680	480	21,420	370
		8	0.008	27,200	630	24,000	520	22,400	420	20,160	380	19,040	300
0.4	0.8	0.5	0.08	34,000	1,090	30,000	900	28,000	780	25,200	710	23,800	550
		1	0.08	34,000	1,090	30,000	900	28,000	780	25,200	710	23,800	550
		1.5	0.08	34,000	1,090	30,000	900	28,000	780	25,200	710	23,800	550
		2	0.064	34,000	1,090	30,000	900	28,000	780	25,200	710	23,800	550
		2.5	0.06	34,000	1,090	30,000	900	28,000	780	25,200	710	23,800	550
		3	0.055	34,000	1,090	30,000	900	28,000	780	25,200	710	23,800	550
		4	0.045	34,000	1,090	30,000	900	28,000	780	25,200	710	23,800	550
		5	0.036	30,600	880	27,000	730	25,200	640	22,680	570	21,420	450
		6	0.026	30,600	880	27,000	730	25,200	640	22,680	570	21,420	450
		8	0.016	27,200	780	24,000	650	22,400	560	20,160	510	19,040	400
10	0.008	27,200	740	24,000	610	22,400	530	20,160	480	19,040	370		
12	0.006	27,200	740	24,000	610	22,400	530	20,160	480	19,040	370		
0.45	0.9	0.6	0.072	32,300	1,220	28,500	1,000	26,600	890	23,940	800	22,610	620
		2	0.072	32,300	1,220	28,500	1,000	26,600	890	23,940	800	22,610	620
		4	0.046	32,300	1,220	28,500	1,000	26,600	890	23,940	800	22,610	620
		6	0.034	29,070	980	25,650	810	23,940	720	21,550	650	20,350	510
		8	0.024	25,840	880	22,800	720	21,280	640	19,150	580	18,090	450
0.5	1	0.8	0.09	30,600	1,380	27,000	1,130	25,200	1,010	22,680	910	21,420	710
		1.5	0.09	30,600	1,380	27,000	1,130	25,200	1,010	22,680	910	21,420	710
		2	0.08	30,600	1,380	27,000	1,130	25,200	1,010	22,680	910	21,420	710
		2.5	0.08	30,600	1,380	27,000	1,130	25,200	1,010	22,680	910	21,420	710
		3	0.08	30,600	1,380	27,000	1,130	25,200	1,010	22,680	910	21,420	710
		4	0.056	30,600	1,380	27,000	1,130	25,200	1,010	22,680	910	21,420	710
		5	0.048	30,600	1,380	27,000	1,130	25,200	1,010	22,680	910	21,420	710
		6	0.032	27,540	1,120	24,300	920	22,680	820	20,410	730	19,280	570
		7	0.032	27,540	1,120	24,300	920	22,680	820	20,410	730	19,280	570
		8	0.032	27,540	1,120	24,300	920	22,680	820	20,410	730	19,280	570
		9	0.024	27,540	1,120	24,300	920	22,680	820	20,410	730	19,280	570
		10	0.02	27,540	1,120	24,300	920	22,680	820	20,410	730	19,280	570
		12	0.01	24,480	940	21,600	770	20,160	690	18,140	620	17,140	480
		13	0.009	24,480	940	21,600	770	20,160	690	18,140	620	17,140	480
		14	0.008	24,480	940	21,600	770	20,160	690	18,140	620	17,140	480
16	0.006	24,480	940	21,600	770	20,160	690	18,140	620	17,140	480		
18	0.005	21,420	770	18,900	640	17,640	560	15,880	510	14,990	400		
20	0.004	18,360	660	16,200	540	15,120	480	13,610	440	12,850	340		

【注意】 ご使用にあたっては、21ページの表下の項目と注意を参照してください。 **【Note】** Upon usage, please refer to comments and notes below table on page 21.

標準切削条件表

Recommended Cutting Conditions

高能率切削条件
High efficiency cutting condition

高精度切削条件
High accuracy cutting condition

高能率切削条件は14ページを参照してください。Please refer to P.14 about high efficiency cutting conditions

被削材 Work material				1		2		3		4		5	
				プリハードン鋼 Pre-hardened steels (35~45HRC)		焼入れ鋼 Hardened steels (45~55HRC)		焼入れ鋼 Hardened steels (55~65HRC)		焼入れ鋼 Hardened steels (65~68HRC)		焼入れ鋼 Hardened steels (68~72HRC)	
切り込み比率 Ratio to standard depth of cut				100%		85%		80%		65%		55%	
ボール半径RE Ball radius (mm)	外径DC Tool dia. (mm)	首下長LU Under neck length (mm)	ap (mm)	回転数 n min ⁻¹	送り速度 Vf mm/min	回転数 n min ⁻¹	送り速度 Vf mm/min	回転数 n min ⁻¹	送り速度 Vf mm/min	回転数 n min ⁻¹	送り速度 Vf mm/min	回転数 n min ⁻¹	送り速度 Vf mm/min
0.55	1.1	2	0.08	28,560	1,300	25,200	1,090	23,520	970	21,170	870	19,990	680
		4	0.056	28,560	1,300	25,200	1,090	23,520	970	21,170	870	19,990	680
		6	0.032	26,010	1,090	22,950	920	21,420	810	19,280	730	18,210	570
		8	0.032	26,010	1,090	22,950	920	21,420	810	19,280	730	18,210	570
		10	0.02	26,010	1,090	22,950	920	21,420	810	19,280	730	18,210	570
0.6	1.2	2	0.077	26,150	1,210	23,080	1,000	21,540	890	19,380	800	18,310	620
		3	0.077	26,150	1,210	23,080	1,000	21,540	890	19,380	800	18,310	620
		4	0.064	26,150	1,210	23,080	1,000	21,540	890	19,380	800	18,310	620
		6	0.048	26,150	1,210	23,080	1,000	21,540	890	19,380	800	18,310	620
		8	0.032	24,480	1,220	21,600	950	20,160	810	18,140	730	17,140	560
		10	0.028	24,480	1,100	21,600	860	20,160	730	18,140	650	17,140	510
		12	0.024	24,480	1,100	21,600	860	20,160	730	18,140	650	17,140	510
0.7	1.4	3	0.088	21,420	1,160	18,900	980	17,640	880	15,880	790	14,990	620
		8	0.044	21,420	1,160	18,900	980	17,640	880	15,880	790	14,990	620
		12	0.028	21,420	1,040	18,900	890	17,640	790	15,880	720	14,990	560
		16	0.014	19,040	870	16,800	740	15,680	670	14,110	600	13,330	470
0.75	1.5	2	0.096	23,800	1,430	21,000	1,130	19,600	980	17,640	880	16,660	690
		2.5	0.096	23,800	1,430	21,000	1,130	19,600	980	17,640	880	16,660	690
		3	0.096	23,800	1,430	21,000	1,130	19,600	980	17,640	880	16,660	690
		4	0.08	23,800	1,430	21,000	1,130	19,600	980	17,640	880	16,660	690
		5	0.08	23,800	1,430	21,000	1,130	19,600	980	17,640	880	16,660	690
		6	0.08	23,800	1,430	21,000	1,130	19,600	980	17,640	880	16,660	690
		8	0.048	21,420	1,160	18,900	920	17,640	790	15,880	720	14,990	560
		10	0.048	21,420	1,160	18,900	920	17,640	790	15,880	720	14,990	560
		12	0.048	21,420	1,160	18,900	920	17,640	790	15,880	720	14,990	560
		14	0.04	19,040	970	16,800	770	15,680	670	14,110	600	13,330	470
		16	0.015	19,040	970	16,800	770	15,680	670	14,110	600	13,330	470
0.8	1.6	4	0.11	22,100	1,370	19,500	1,170	18,200	1,020	16,380	920	15,470	710
		8	0.088	22,100	1,370	19,500	1,170	18,200	1,020	16,380	920	15,470	710
		12	0.052	19,890	1,110	17,550	950	16,380	830	14,740	740	13,920	580
		16	0.032	19,890	1,110	17,550	950	16,380	830	14,740	740	13,920	580
		20	0.016	17,680	930	15,600	800	14,560	690	13,100	620	12,380	490
0.9	1.8	4	0.147	22,100	1,550	19,500	1,290	18,200	1,090	16,380	980	15,470	760
		8	0.104	22,100	1,550	19,500	1,290	18,200	1,090	16,380	980	15,470	760
		12	0.056	19,890	1,250	17,550	1,040	16,380	890	14,740	800	13,920	620
		16	0.036	19,890	1,250	17,550	1,040	16,380	890	14,740	800	13,920	620
		20	0.018	17,680	1,050	15,600	880	14,560	740	13,100	670	12,380	520
1	2	2.5	0.16	17,850	1,610	15,750	1,360	14,700	1,180	13,230	1,060	12,500	820
		3	0.16	17,850	1,610	15,750	1,360	14,700	1,180	13,230	1,060	12,500	820
		4	0.16	17,850	1,610	15,750	1,360	14,700	1,180	13,230	1,060	12,500	820
		5	0.16	17,850	1,610	15,750	1,360	14,700	1,180	13,230	1,060	12,500	820
		6	0.16	17,850	1,430	15,750	1,200	14,700	1,060	13,230	950	12,500	740
		8	0.112	17,850	1,430	15,750	1,200	14,700	1,060	13,230	950	12,500	740
		10	0.112	17,850	1,290	15,750	1,070	14,700	940	13,230	850	12,500	660
		12	0.064	16,070	1,160	14,180	960	13,230	850	11,910	760	11,250	590
		13	0.064	16,070	1,160	14,180	960	13,230	850	11,910	760	11,250	590
		14	0.064	16,070	1,160	14,180	960	13,230	850	11,910	760	11,250	590
		16	0.064	16,070	1,040	14,180	870	13,230	760	11,910	690	11,250	530
		18	0.048	16,070	1,040	14,180	870	13,230	760	11,910	690	11,250	530
		20	0.04	16,070	1,040	14,180	870	13,230	760	11,910	690	11,250	530
		22	0.034	15,170	930	13,390	770	12,500	680	11,250	610	10,620	480
		25	0.028	14,280	870	12,600	730	11,760	640	10,580	580	10,000	450
		30	0.012	14,280	870	12,600	730	11,760	640	10,580	580	10,000	450
35	0.01	12,500	720	11,030	600	10,290	530	9,260	470	8,750	370		
40	0.008	10,710	620	9,450	510	8,820	450	7,940	410	7,500	320		

高効率切削条件
High efficiency cutting condition

高精度切削条件
High accuracy cutting condition

高効率切削条件は14ページを参照してください。Please refer to P.14 about high efficiency cutting conditions

被削材 Work material				1		2		3		4		5		
				プリハードン鋼 Pre-hardened steels (35~45HRC)		焼入れ鋼 Hardened steels (45~55HRC)		焼入れ鋼 Hardened steels (55~55HRC)		焼入れ鋼 Hardened steels (65~68HRC)		焼入れ鋼 Hardened steels (68~72HRC)		
切り込み比率 Ratio to standard depth of cut				100%		85%		80%		65%		55%		
ボール半径RE Ball radius (mm)	外径DC Tool dia. (mm)	首下長LU Under neck length (mm)	ap (mm)	回転数 n min ⁻¹	送り速度 Vf mm/min	回転数 n min ⁻¹	送り速度 Vf mm/min	回転数 n min ⁻¹	送り速度 Vf mm/min	回転数 n min ⁻¹	送り速度 Vf mm/min	回転数 n min ⁻¹	送り速度 Vf mm/min	
1.25	2.5		6	0.2	15,730	1,690	13,880	1,370	12,950	1,130	11,660	1,010	11,070	810
			10	0.136	15,730	1,690	13,880	1,370	12,950	1,130	11,660	1,010	11,070	810
			15	0.08	14,150	1,370	12,490	1,110	11,660	910	10,490	820	9,970	660
			20	0.064	14,150	1,370	12,490	1,110	11,660	910	10,490	820	9,970	660
			25	0.052	14,150	1,230	12,490	1,000	11,660	820	10,490	740	9,970	590
			30	0.035	12,580	1,150	11,100	930	10,360	770	9,320	690	8,860	550
1.5	3		6	0.24	13,600	1,820	12,000	1,510	11,200	1,340	10,080	1,210	9,580	970
			8	0.24	13,600	1,820	12,000	1,510	11,200	1,340	10,080	1,210	9,580	970
			10	0.168	13,600	1,820	12,000	1,510	11,200	1,340	10,080	1,210	9,580	970
			13	0.168	13,600	1,820	12,000	1,510	11,200	1,340	10,080	1,210	9,580	970
			16	0.168	13,600	1,640	12,000	1,360	11,200	1,210	10,080	1,090	9,580	870
			20	0.096	12,240	1,480	10,800	1,230	10,080	1,090	9,070	980	8,620	780
			25	0.064	12,240	1,480	10,800	1,230	10,080	1,090	9,070	980	8,620	780
			30	0.064	12,240	1,480	10,800	1,230	10,080	1,090	9,070	980	8,620	780
1.75	3.5		10	0.216	11,690	1,760	10,310	1,430	9,630	1,180	8,660	1,060	8,230	850
			15	0.192	11,690	1,760	10,310	1,430	9,630	1,180	8,660	1,060	8,230	850
			25	0.112	10,520	1,430	9,280	1,160	8,660	950	7,800	860	7,410	680
			35	0.072	10,520	1,430	9,280	1,160	8,660	950	7,800	860	7,410	680
			45	0.058	9,350	1,200	8,250	980	7,700	800	6,930	720	6,580	580
2	4		8	0.32	9,780	1,760	8,630	1,470	8,050	1,290	7,250	1,160	6,880	930
			10	0.32	9,780	1,760	8,630	1,470	8,050	1,290	7,250	1,160	6,880	930
			12	0.256	9,780	1,760	8,630	1,470	8,050	1,290	7,250	1,160	6,880	930
			13	0.256	9,780	1,760	8,630	1,470	8,050	1,290	7,250	1,160	6,880	930
			16	0.224	9,780	1,760	8,630	1,470	8,050	1,290	7,250	1,160	6,880	930
			20	0.224	9,780	1,760	8,630	1,470	8,050	1,290	7,250	1,160	6,880	930
			25	0.128	8,800	1,430	7,760	1,190	7,250	1,040	6,520	940	6,190	750
			30	0.128	8,800	1,430	7,760	1,190	7,250	1,040	6,520	940	6,190	750
			35	0.08	8,800	1,430	7,760	1,190	7,250	1,040	6,520	940	6,190	750
			40	0.08	8,800	1,430	7,760	1,190	7,250	1,040	6,520	940	6,190	750
2.5	5		10	0.392	7,650	1,530	6,750	1,350	6,300	1,130	5,670	1,020	5,390	820
			20	0.28	7,650	1,530	6,750	1,350	6,300	1,130	5,670	1,020	5,390	820
			25	0.28	7,650	1,530	6,750	1,350	6,300	1,130	5,670	1,020	5,390	820
			30	0.16	6,890	1,380	6,080	1,220	5,670	1,020	5,100	920	4,850	740
			40	0.16	6,890	1,240	6,080	1,090	5,670	920	5,100	830	4,850	660
3	6		12	0.48	7,650	1,890	6,750	1,540	6,300	1,260	5,670	1,130	5,390	910
			20	0.4	7,230	1,660	6,380	1,350	5,950	1,110	5,360	990	5,090	800
			30	0.336	6,800	1,360	6,000	1,200	5,600	1,010	5,040	910	4,790	730
			50	0.12	6,120	1,100	5,400	970	5,040	820	4,540	730	4,310	590
4	8	24	0.5	6,400	1,690	5,720	1,320	4,180	1,170	3,960	870	3,760	700	
5	10	30	0.6	5,100	1,460	4,510	1,130	3,520	1,000	3,190	770	3,030	620	
6	12	36	0.8	4,200	1,240	3,850	1,000	2,640	880	2,640	660	2,510	530	

※(1) apは被削材グループ1での目安を示しています。その他のグループの場合は、上表の切り込み比率を目安に調整してください。

※(2) リブ加工や止まり溝など、切りくすがつまりやすい切削の場合、切り込み設定は基本切り込み切り込み比率をかけて算出した切り込み量を、さらにその80%まで小さくして使用してください。

※(3) aeの設定はap×切り込み比率×3~5倍を目安に調整してください。仕上げ加工を行う場合、理論カスプハイトを計算し設定してください。

※(1) ap is shown as the criteria for Group 1 workpieces. For other groups, adjust the cutting depth according to the cutting depth factors in the above table.

※(2) When performing cutting where cutting chips may cause clogging, such as for rib cutting, blind grooves, etc., cutting depth setting should be set by multiplying a cutting depth factor to calculate the cutting depth amount, and this amount should then be reduced to 80% of the calculated value.

※(3) Adjust by setting ae to (3 to 5) × (ap) × (cutting depth ratio). When performing finishing processing, calculate the theoretical cusp height and set accordingly.

【切り込み設定例】 EPDBEH2020-10-TH3の工具で焼入れ鋼(50HRC)をリブ溝等高線切削する場合、
切り込み=0.112(ap)×0.85(焼入れ鋼グループ2の切り込み比率)×0.8(閉鎖域の切削)=0.076mm

Cutting depth setting example: When cutting rib groove contours in hardened steel (50HRC) using an EPDBEH2020-10-TH3 tool:
Cutting depth = 0.112 (ap) × 0.85 (cutting depth factor for Group 2 hardened steel) × 0.8 (for closed-area cutting) = 0.076mm

【注意】 ①基本的にはDry(エアブロー)切削を推奨しますが、被削材、加工形状に合わせて、適切なクーラントを使用してください。
②この標準切削条件表は切削条件の目安を示すものです。実際の加工では加工形状、目的、使用機械等により条件を調整してください。
③機械の回転数が足りない場合は、回転数と送り速度を同じ比率で下げてください。

【Note】 ① Although basically dry (air blow) cutting is recommended, please use appropriate coolant according to the work material and machining shape.
② These Recommended Cutting Conditions indicate only the rule of a thumb for the cutting conditions. In actual machining, the condition should be adjusted according to the machining shape, purpose and the machine type.
③ If the rpm of the machine is low, lower the feed rate also to put the rpm and feed rate in the same ratio.

○ cBN工具との比較事例

Comparison with cBN tool

評価工具 Tools

EPDBEH2010-2.5-TH3
(φ1 首下長 Under neck length 2.5mm)

加工環境 Machining environment

使用機械：立型MC (HSK-E32)
Machine: vertical MC

被削材：PD613 (60HRC)
Work material

クーラント：ミストブロー
Coolant: Mist-blow

切削条件 Cutting conditions

$n=40,000\text{min}^{-1}$ ($v_c=126\text{m/min}$)
 $v_f=1,600\text{mm/min}$ ($f_z=0.02\text{mm/t}$)
 $a_p \times a_e=0.02 \times 0.02\text{mm}$

EPDBEH-TH3



光沢がある加工面
Shiny machined surface



cBN



白濁した加工面
Cloudy machined surface



測定箇所
Measurement point



先端部の摩滅が小さい
Minimal tip wear



先端部の摩滅が大きい
Significant tip wear

cBNに迫る寿命と加工精度・高品位な加工面により磨き工数を削減

Tool life and machining accuracy approaching cBN; reduced polishing man-hours due to quality machined surfaces

○ 球面レンズ形状の鏡面仕上げ加工

Spherical lens profile mirror-finish machining

工具 Tool：EPDBEH2020-4-TH3 (φ2 首下長 Under neck length 4mm)
被削材 Work material：STAVAX (52HRC) 機械 Machine：立型MC(HSK-E32) Vertical MC
切削条件 Cutting conditions： $n=40,000\text{min}^{-1}$ ($v_c=250\text{m/min}$) $v_f=400\text{mm/min}$ ($f_z=0.005\text{mm/t}$)
加工ピッチ Pitch：0.0025mm 仕上げ代 Finishing allowance：0.005mm
クーラント Coolant：水溶性切削液 Water base ※cBNのみミストブロー Mist blow for cBN only

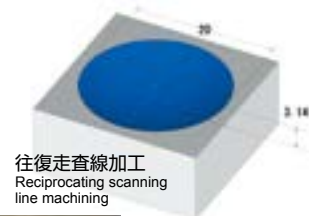

最もムラが少ない均一な外観品位で表面粗さもPCDと同等レベルを達成

Uniform visual appearance with minimal irregularities and surface roughness on same level as PCD



高速度工具鋼の加工事例

Field data of High-speed steel cutting

01 粉末ハイス鋼の直彫り加工 **[HAP40 65HRC]** Direct cutting of powdered high-speed steel

工具 Tool : EPDBEH2010-3-TH3 (φ1 首下長 Under neck length 3mm) 被削材 Work material : HAP40 65HRC
 機械 Machine : 立型MC (HSK-F63) Vertical MC 加工方法 Cutting method : 等高線ポケット加工 Contour pocketing
 切削条件 Cutting conditions : $n=24,000\text{min}^{-1}$ ($v_c=75\text{m/min}$) $v_f=860\text{mm/min}$ ($f_z=0.018\text{mm/t}$)
 a_p 0.04mm a_e 0.04mm Dry (エアブロー Air-blow)

図 30分加工後の摩耗状態 Figure: Wear condition after 30 minutes of machining

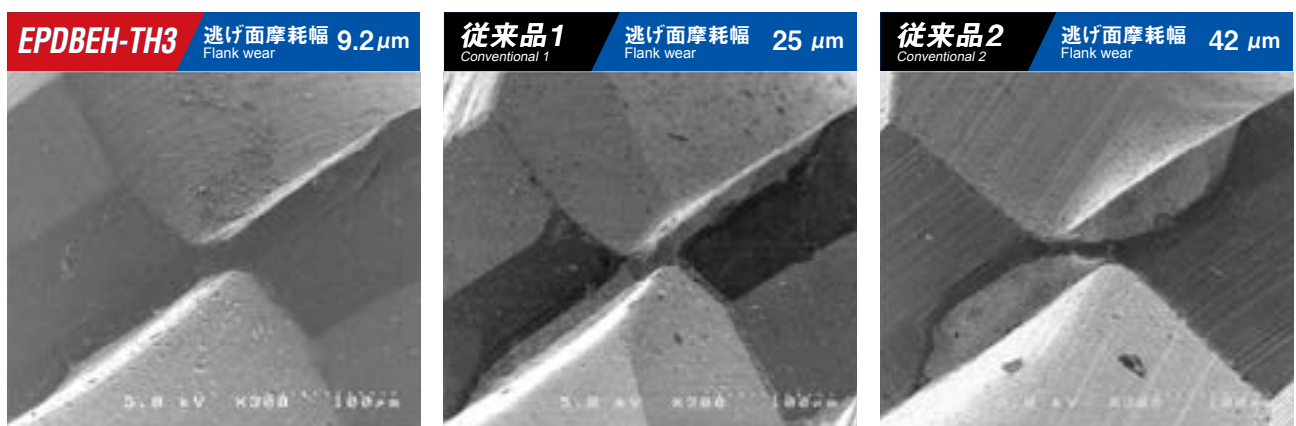

摩耗量は従来品の1/3以下!!優れた耐摩耗性を発揮

Wear amount is 1/3 that of conventional products!! Demonstrates excellent wear resistance.

02 マトリックス系ハイス鋼のポケット加工 **[YXR33 58HRC]** Pocketing of matrix high-speed steel

ポケットサイズ Pocket size : 12.8×10.8×5mm
 工具 Tool : EPDBEH2010-6-TH3 (φ1 首下長 Under neck length 6mm) 被削材 Work material : YXR33 58HRC
 機械 Machine : 立型MC (HSK-E32) Vertical MC
 切削条件 Cutting conditions : $n=22,600\text{min}^{-1}$ ($v_c=71\text{m/min}$) $v_f=820\text{mm/min}$ ($f_z=0.018\text{mm/t}$)
 a_p 0.025mm a_e 0.125mm OH=18mm クーラント Coolant : ミストブロー Mist blow

図 60分加工後の摩耗状態 Figure: Wear condition after 60 minutes of machining

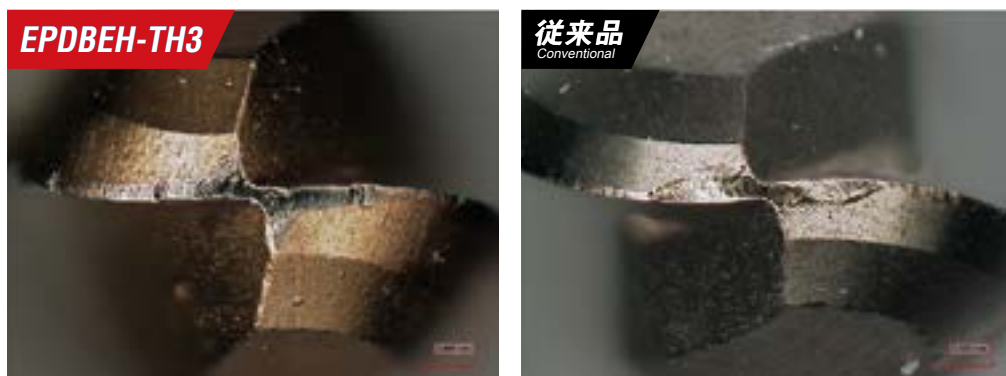

1時間加工後も摩耗量はわずか11μm

The amount of wear was only 11μm even after processing for 1 hour.

○ 高速度工具鋼の加工事例

Field data of High-speed steel cutting

03 溶製ハイス鋼 **[DURO-V5 62-63HRC]** Dissolution high-speed steel DURO-V5

工具 Tool : EPDBEH2010-2-TH3 (φ1 首下長 Under neck length 2mm) 被削材 Work material : DURO-V5(62-63HRC)
 機械 Machine : 5軸MC(BT40) 5-axis MC
 切削条件 Cutting conditions : $n=17,000\text{min}^{-1}$ ($v_c=53\text{m/min}$) $v_f=800\text{mm/min}$ ($f_z=0.04\text{mm/t}$)
 $a_p 0.023\text{mm}$ $a_e 0.05\text{mm}$ 仕上げ代 Stock material 0.015mm クーラント Coolant : ミストブロー Mist blow
 加工時間 Cutting time : 45分 min

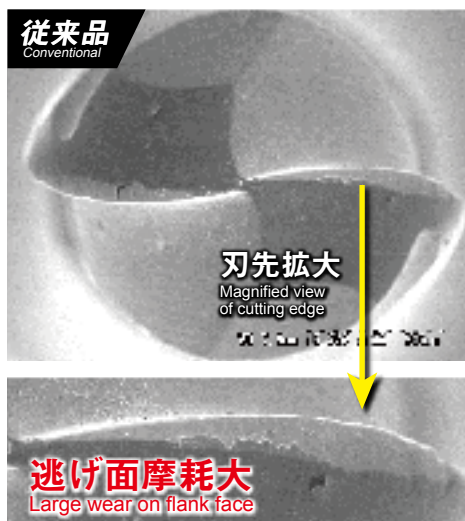

○ プラスチック金型鋼の加工事例

Field data of plastic mold steel cutting

01 SUS420J2相当材の加工事例 **[TH3 文字彫り加工]** Cutting of equivalent to SUS420J2 Relief engraving of "TH3"

機械 : 立型MC(HSK-E25) 被削材 : HPM38(57HRC) クーラント : ミストブロー
 Machine: Vertical MC(HSK-E25) Work material: HPM38(57HRC) Coolant: Mist-blow

図 仕上げ加工後の摩耗状態 Figure: Wear condition after finishing

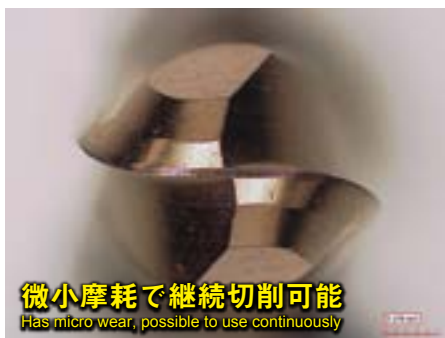

(R0.75-首下長2mm Under neck length 2mm)

図 加工ワーク Figure: Work



ワークサイズ Work size : 50×50×10mm

加工工程 Process	商品コード Item code	工具径 Tool dia. (mm)	首下長 Under neck length (mm)	回転数 Revolution (min^{-1})	切削速度 Cutting speed (m/min)	送り速度 Feed rate (mm/min)	一刃送り Feed per tooth (mm/t)	a_p (mm)	a_e (mm)	加工時間 Cutting time
荒 Roughing	EPDBEH2030-8-TH3	φ3.0	8	21,221	100	2,122	0.05	0.2	0.4	38分 min
仕上げ Finishing	EPDBEH2015-2-TH3	φ1.5	2	40,000	188	2,400	0.03	0.04	0.104	76分 min

トータル Total 1時間hr 54分min

02 SUS440C 相当材の高効率加工事例 High speed cutting of equivalent to SUS440C

図 加工モデル Figure : Work shape

ワークサイズ : 50×50×10mm
Work size



図 加工ワーク拡大 Figure : Magnified view

20° 緩斜面の面粗さ
Surface roughness of
20° incline

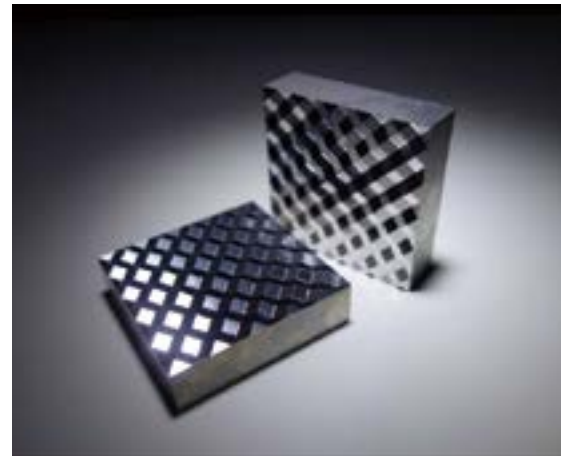
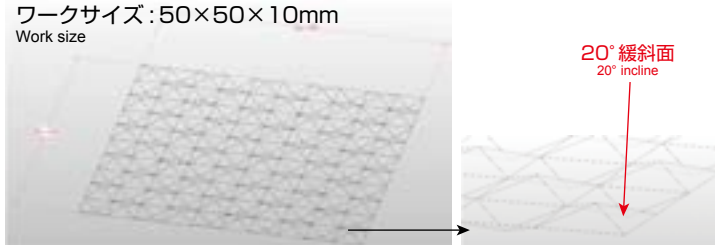
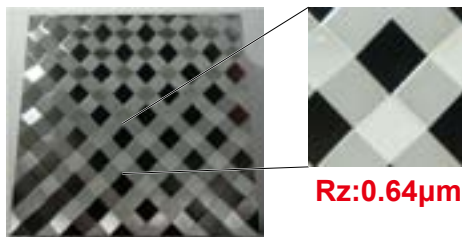

機械 : 立型 MC(HSK-E25) 被削材 : SUS440C(60HRC) クーラント : ミストブロー
Machine: Vertical MC(HSK-E25) SUS440C(60HRC) Coolant: Mist-blow

加工工程 Process	商品コード Item code	工具径 Tool dia. (mm)	首下長 Under neck length (mm)	回転数 Revolution (min ⁻¹)	切削速度 Cutting speed (m/min)	送り速度 Feed rate (mm/min)	一刃送り Feed per tooth (mm/t)	ap (mm)	ae (mm)	加工時間 Cutting time
荒 Roughing	EPDBEH2030-8-TH3	φ3.0	8	10,610	100	1,061	0.05	0.3	0.3	60分 min
中仕上げ Semi-finishing	EPDBEH2030-8-TH3	φ3.0	8	15,915	150	1,592	0.05	0.1	0.1	28分 min
仕上げ Finishing	EPDBEH2010-2-TH3	φ1.0	2	31,831	100	1,910	0.03	0.03	0.03	56分 min

トータル Total 2時間hr 24分min

03 SUS440C 相当材 【M340 57HRC】 Equivalent to SUS440C M340

工具 Tool : EPDBEH2020-10-TH3 (φ2 首下長 Under neck length 10mm) 被削材 Work material : M340 (57HRC)

機械 Machine : 立型MC(HSK-E32) Vertical MC

切削条件 Cutting conditions : $n=15,000\text{min}^{-1}$ ($v_c=94\text{m/min}$) $v_f=600\text{mm/min}$ ($f_z=0.02\text{mm/t}$)

a_p 0.12mm a_e 0.15mm クーラント Coolant : ミストブロー Mist blow 加工時間 Cutting time : 180分 min



逃げ面摩耗幅 : 0.021mm
Frank wear width

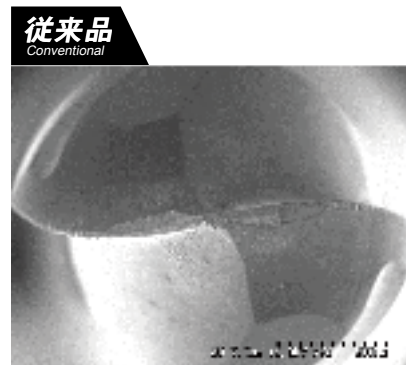

従来品
Conventional
逃げ面摩耗幅 : 0.091mm
Frank wear width

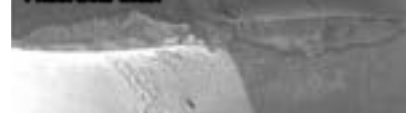



多数個取りポケット形状モデル加工

Multi-cavity model pocketing

図 加工モデル Figure : Work shape

ポケット形状寸法 8mm×8mm×深さ5mm
Pocket size: 8mm×8mm×depth 5mm



図 加工後ワーク Figure : Work after machining

トータル100個のポケットを加工

Processed total 100 of pockets

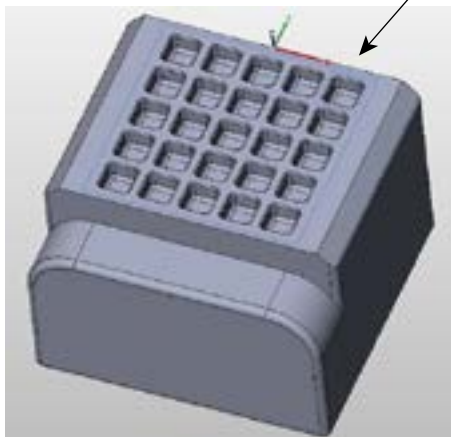

機械：5軸MC (HSK-A63) 被削材：SUS420J2相当 (52HRC) クーラント：ドライ (エア)
Machine : 5-axis MC Work material : Equivalent to SUS420J2(52HRC) Coolant : Dry(air)

加工工程 Process	商品コード Item code	工具径 Tool dia. (mm)	回転数 Revolution (min ⁻¹)	切削速度 Cutting speed (m/min)	送り速度 Feed rate (mm/min)	一刃送り Feed per tooth (mm/t)	ap (mm)	ae (mm)	残し代 Removal stock (mm)	加工時間 Cutting time (min)
等高線荒加工 Contour roughing	EPDBEH2030-8-TH3	φ3.0	11,200	105	1,344	0.06	0.3	0.7	0.05	47分
等高線中仕上げ加工 Contour semi finishing	EPDBEH2020-6-TH3	φ2.0	14,700	92	1,058	0.035	0.2	—	0.02	25分
等高線仕上げ加工 Contour finishing	EPDBEH2020-6-TH3	φ2.0	14,700	92	1,058	0.035	0.1	0.02	0	37分
等高線仕上げ加工(底面) Contour bottom finishing	EPDBEH2020-6-TH3	φ2.0	14,700	92	1,058	0.035	—	0.02	0	49分

※加工時間は1ワーク(ポケット25個加工の時間)
Cutting time per work (25 pockets)

■ 工具摩耗状態 Tool wear condition

EPDBEH2020-6-TH3

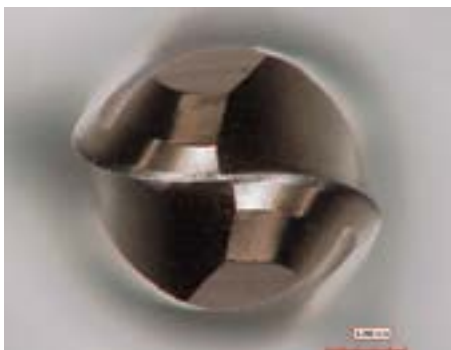

逃げ面摩耗幅：0.023mm
Flank wear width

■ ワーク削り残り量 Amount of cutting remain

ポケットの幅を測定
Measures pocket width



片側削り残り量：0.0035mm～0.012mm
(100ポケット内変化量：0.0085mm)
Cutting remain per one side : 0.0035 mm～0.012 mm
(variation in 100 pockets: 0.0085 mm)

中仕上げと仕上げ工程を1本で加工可能!!

加工時間はなんと7時間24分!!

Finalized semi-finishing and finishing by 1 tool.
Machining time is 7 hours and 24 minutes!

削り残り量も0.012mmと非常に少なく

高精度な加工が可能。

Cutting remain is very small, only 0.012mm and achieved
very precise machining.



粉末ハイス直彫りポケット加工

Direct pocketing of powder high-speed steel

機 械 Machine : 立型MC (HSK-E32) Vertical MC
 被削材 Work material : HAP40(65HRC)
 クーラント Coolant : ミストブロー Mist-blow

図 加工モデル Figure : Work shape

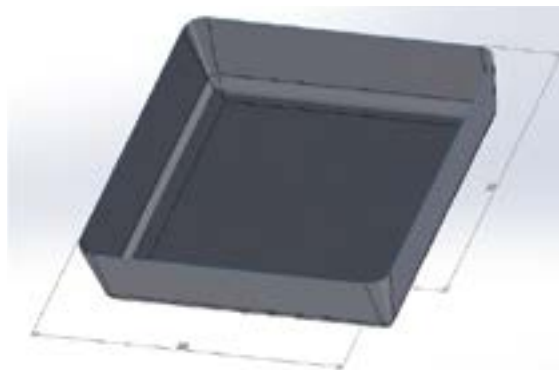

ポケットサイズ : 20×20×5mm (勾配角 10°)
 Pocket size : 20×20×5mm (Incline angle 10°)

加工工程 Process	商品コード Item code	工具径 Tool dia. (mm)	回転数 Revolution (min ⁻¹)	切削速度 Cutting speed (m/min)	送り速度 Feed rate (mm/min)	一刃送り Feed per tooth (mm/t)	ap (mm)	ae (mm)	残し代 Removal stock (mm)	加工時間 Cutting time (min)
等高線荒加工 Contour roughing	EPDBEH2030-8-TH3	φ3.0	11,200	106	1,344	0.06	0.18	0.18	0.05	39分 min
等高線仕上げ加工 Contour finishing	EPDBEH2020-6-TH3	φ2.0	22,680	143	816	0.018	0.02	0.02	0	20分 min
走査線仕上げ加工 Parallel finishing	EPDBEH2020-6-TH3	φ2.0	22,680	143	816	0.018	0.02	0.02	0	16分 min

トータル Total 75分 min

削り残り量比較 Comparison of cutting remain

図 2ポケット加工後の削り残り量と工具摩耗の関係

Figure : Correlation chart of cutting remain and tool wear after 2 pockets processing

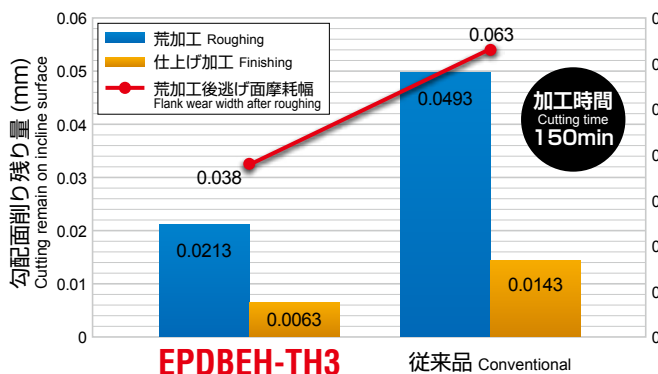

加工ワーク面粗さ Machined surface roughness

図 2ポケット加工後のワーク

Figure : Work after 2 pocketing

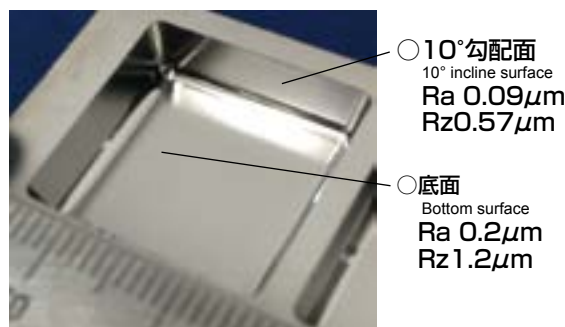

Hi-Pre²

TH3の優れた耐摩耗性と高剛性刃形の相乗効果で、粉末ハイスの直彫り加工において削り残り量を低減し、良好な加工面粗さを実現します

The synergy of the superior wear resistance of TH3 Coating and high-rigidity cutting edge geometry reduces the cutting remain on direct cutting of powder high-speed steel and realizes good machined surface roughness

Hi-Pre²とは? “High Precision Pre-finishing” の略です。(読み:ハイ・プレッサー)

再研磨対応範囲一覧表 Re-grinding compatibility range table

商品コード Item code	商品名称 Product	形状 Shape	再研磨対応外径範囲 (mm) Re-grinding compatibility range	
			外周 Outer dia.	エンド End
EPDBEH-TH3	エポックディープボールエボリューションハード-TH3 Epoch Deep Ball Evolution Hard-TH3		× (N/A)	4~12

【注意】 L/D(首下長/外径)が10DCを超える工具の再研磨可否については、弊社営業にお問い合わせください。

【Note】 Contact our sales office regarding whether or not re-grinding is possible for tools where L/D(under neck length / tool diameter) more than 10DC



図、表等のデータは試験結果の一例であり、保証値ではありません。
「MOLDINO」は株式会社MOLDINOの登録商標です。

The diagrams and table data are examples of test results, and are not guaranteed values.
“MOLDINO” is a registered trademark of MOLDINO Tool Engineering, Ltd.

安全上のご注意 Attention on Safety

1. 取扱上のご注意

- (1) 工具をケース(梱包)から取り出す際は、工具の飛び出し、落下にご注意ください。特に工具刃部との接触には十分ご注意ください。
- (2) 鋭利な切れ刃を有する工具を取扱う際は、切れ刃を素手で直接触れないように注意してください。

2. 取付け時のご注意

- (1) ご使用前に、工具の傷、割れ等の外観確認を行っていただき、コレットチャック等への取付けは確実に行ってください。
- (2) ご使用中に、異常な振動等が発生した場合は、直ちに機械を停止させて、その振動の原因を取り除いてください。

3. 使用上のご注意

- (1) 切削工具あるいは被削材の寸法・回転の方向は、あらかじめ確認しておいてください。
- (2) 標準切削条件表の数値は、新しい作業の立上げの目安としてご利用ください。切込みが大きい場合、使用機械の剛性が小さい場合あるいは被加工物の性状に応じて切削条件を適正に調整してご使用ください。
- (3) 切削工具材料は硬質の材料です。ご使用中に破損して飛散する場合があります。また、切りくずが飛散することがあります。これらの飛散物等は作業者を切傷させ、火傷あるいは目に入って負傷させる恐れがありますので、工具をご使用中はその周囲に安全カバーを取付け、保護めがね等の保護具を着用して安全な環境下での作業をお願いします。
- (4) 切削中に発生する火花や、破損による発熱や、切りくずによる引火・火災の危険があります。引火や爆発の危険のあるところでは使用しないでください。不水溶性切削液をご使用される場合は防火対策を必ず行ってください。
- (5) 工具を本来の目的以外にはご使用にならないでください。

4. 再研削時のご注意

- (1) 再研削時期が不相当であると工具が破損する恐れがあります。適正な工具と交換するか、再研削を行ってください。
- (2) 工具を再研削しますと粉塵が発生します。再研削時にはその周囲に安全カバーを取付け、保護めがね等の保護具を着用してください。
- (3) 本製品には特定化学物質に指定されたコバルト及びその無機化合物が含まれています。再研削等の加工を加える場合は特定化学物質障害予防規則(特化規則)に従った取扱いをしてください。

5. 工具に関して、安全上の問題点・不明の点・その他相談がありましたら [フリーダイヤル技術相談](#)へご相談ください。

1. Cautions regarding handling

- (1) When removing the tool from its case (packaging), be careful that the tool does not pop out or is dropped. Be particularly careful regarding contact with the tool flutes.
- (2) When handling tools with sharp cutting flutes, be careful not to touch the cutting flutes directly with your bare hands.

2. Cautions regarding mounting

- (1) Before use, check the outside appearance of the tool for scratches, cracks, etc. and that it is firmly mounted in the collet chuck, etc.
- (2) If abnormal chattering, etc. occurs during use, stop the machine immediately and remove the cause of the chattering.

3. Cautions during use

- (1) Before use, confirm the dimensions and direction of rotation of the tool and milling work material.
- (2) The numerical values in the standard cutting conditions table should be used as criteria when starting new work. The cutting conditions should be adjusted as appropriate when the cutting depth is large, the rigidity of the machine being used is low, or according to the conditions of the work material.
- (3) Cutting tools are made of a hard material. During use, they may break and fly off. In addition, cutting chips may also fly off. Since there is a danger of injury to workers, fire, or eye damage from such flying pieces, a safety cover should be attached when work is performed and safety equipment such as safety goggles should be worn to create a safe environment for work.
- (4) There is a risk of fire or inflammation due to sparks, heat due to breakage, and cutting chips. Do not use where there is a risk of fire or explosion. Please caution of fire while using oil base coolant, fire prevention is necessary.
- (5) Do not use the tool for any purpose other than that for which it is intended.

4. Cautions regarding regrinding

- (1) If regrinding is not performed at the proper time, there is a risk of the tool breaking. Replace the tool with one in good condition, or perform regrinding.
- (2) Grinding dust will be created when regrinding a tool. When regrinding, be sure to attach a safety cover over the work area and wear safety clothes such as safety goggles, etc.
- (3) This product contains the specified chemical substance cobalt and its inorganic compounds. When performing regrinding or similar processing, be sure to handle the processing in accordance with the local laws and regulations regarding prevention of hazards due to specified chemical substances.

株式会社 MOLDINO
MOLDINO Tool Engineering, Ltd.

本社 〒130-0026 東京都墨田区両国4-31-11(ヒューリック両国ビル8階)
☎ 03-6890-5101 FAX 03-6890-5134
International Sales Dept. ☎ +81-3-6890-5103 FAX +81-3-6890-5128

営業企画部	☎ 03-6890-5102 FAX03-6890-5134	海外営業部	☎ 03-6890-5103 FAX03-6890-5128
東京営業所	☎ 03-6890-5110 FAX03-6890-5133	静岡営業所	☎ 054-273-0360 FAX054-273-0361
東北営業所	☎ 022-208-5100 FAX022-208-5102	名古屋営業所	☎ 052-687-9150 FAX052-687-9144
新潟営業所	☎ 0258-87-1224 FAX0258-87-1158	大阪営業所	☎ 06-7668-0190 FAX06-7668-0194
東関東営業所	☎ 0294-88-9430 FAX0294-88-9432	中四営業所	☎ 082-536-2001 FAX082-536-2003
長野営業所	☎ 0268-21-3700 FAX0268-21-3711	九州営業所	☎ 092-289-7010 FAX092-289-7012
北関東営業所	☎ 0276-59-6001 FAX0276-59-6005		
神奈川営業所	☎ 046-400-9429 FAX046-400-9435		

ヨーロッパ / MOLDINO Tool Engineering Europe GmbH Itterpark 12, 40724 Hilden, Germany. TEL : +49-(0)2103-24820. FAX : +49-(0)2103-248230
アメリカ / MITSUBISHI MATERIALS U.S.A. CORPORATION 41700 Gardenbrook Road, Suite 120, Novi, MI 48375-1320 U.S.A. TEL : +1(248)308-2620. FAX : +1(248)308-2627
メキシコ / MMC METAL DE MEXICO, S.A. DE C.V. Av. La Cañada No.16, Parque Industrial Bernardo Quintana, El Marques, Querétaro, CP 76246, México TEL : +52-442-1926800
ブラジル / MMC METAL DO BRASIL LTDA. Rua Cincinnati Braga, 340 13° andar, Bela Vista - CEP 01333-010 São Paulo - SP, Brasil TEL : +55(11)3506-5600 FAX : +55(11)3506-5677
タイ / MMC Hardmetal (Thailand) Co., Ltd. MOLDINO Division 622 Emporium Tower, Floor 22/1-4, Sukhumvit Road, Klong Tan, Klong Toei, Bangkok 10110, Thailand TEL : +66-(0)2-661-8175 FAX : +66-(0)2-661-8176
インド / MMC Hardmetal India Pvt Ltd. H.O.: Prasad Enclave, #118/119, 1st Floor, 2nd Stage, 5th main, BBMP Ward #1, (New #38), Industrial Suburb, Yeshwanthpura, Bengaluru, 560 022, Karnataka, India. TEL : +91-80-2204-3600

ホームページ <http://www.moldino.com> フリーダイヤル技術相談 ☎0120-134159

工具選定データベース [TOOL SEARCH]

TOOLSEARCH 検索

店名

掲載価格は2022年10月1日改定後の消費税抜きの単価を表示しております。予告なく、改良・改善のために仕様変更することがあります。
Specifications for the products listed in this catalog are subject to change without notice due to replacement or modification.



Printed in JAPAN

2023-4(K)
2017-1:FP